



GR-UT699

Development Board

User Manual

Information furnished by Aeroflex Gaisler AB is believed to be accurate and reliable.

However, no responsibility is assumed by Aeroflex Gaisler AB for its use, nor for any infringements of patents or other rights of third parties which may result from its use.

No license is granted by implication or otherwise under any patent or patent rights of Aeroflex Gaisler AB.

Aeroflex Gaisler AB
Kungsgatan 12
411 19 Göteborg
Sweden

tel +46 31 7758650
fax +46 31 421407
sales@gaisler.com
www.aeroflex.com/gaisler



Copyright © 2009 Aeroflex Gaisler

All information is provided as is. There is no warranty that it is correct or suitable for any purpose, neither implicit nor explicit.

TABLE OF CONTENTS

1	INTRODUCTION.....	7
1.1	Overview.....	7
1.2	References.....	9
1.3	Handling.....	9
1.4	Abbreviations.....	10
2	ELECTRICAL DESIGN.....	11
2.1	Block Diagram.....	11
2.2	UT699 ASIC.....	11
2.3	Memory.....	12
2.3.1	SRAM.....	13
2.3.2	FLASH.....	13
2.3.3	EEPROM.....	13
2.4	CAN Interface.....	13
2.4.1	Configuration of Bus Termination.....	14
2.4.2	Configuration of Slew Rate.....	15
2.5	Spacewire (LVDS) Interfaces.....	15
2.5.1	SPW interface circuit.....	15
2.5.2	SPWCLK.....	16
2.6	Serial Interface.....	17
2.7	Debug Support Unit (DSU) Serial Interface.....	17
2.8	Oscillators and Clock Inputs.....	19
2.8.1	System Clock.....	19
2.8.2	SPW_CLK.....	19
2.8.3	Ethernet Clock.....	19
2.8.4	PCI Clock.....	19
2.9	Power Supply and Voltage Regulation.....	20
2.10	Ethernet Interface.....	20
2.11	PCI Interface.....	21
2.11.1	Host/System Slot Configuration.....	22
2.11.2	Peripheral Slot Configuration.....	23
2.12	Other Interfaces and Circuits.....	24
2.12.1	GPIO.....	24
2.12.2	Reset Circuit and Button.....	24
2.12.3	Watchdog.....	25
2.12.4	JTAG interface.....	25
3	SETTING UP AND USING THE BOARD.....	26
4	INTERFACES AND CONFIGURATION.....	30
4.1	List of Front/Back Panel Connectors.....	30
4.2	List of Oscillators, Switches and LED's.....	39
4.3	List of Jumpers.....	40

LIST OF TABLES

Table 3-1: Default Status of Jumpers/Switches.....	26
Table 4-1: List of Connectors.....	30
Table 4-2: J1 UART-1 - Serial Interface (RS232) connections	32
Table 4-3: J2 RJ45-ETHERNET Connector.....	32
Table 4-4: J3 ASIC– JTAG Connector	32
Table 4-5: J4A (upper connector) CANBUS-1 interface connections.....	33
Table 4-6: J4B (lower connector) CANBUS-0 interface connections.....	33
Table 4-7: J5 SPW-0 interface connections	33
Table 4-8: J6 SPW-1 interface connections	34
Table 4-9: J7 SPW-2 interface connections	34
Table 4-10: J8 SPW-3 interface connections.....	34
Table 4-11: Expansion connector J9 Pin-out.....	36
Table 4-12: J10 PIO Header Pin out.....	36
Table 4-13: Expansion connector J11 Pin-out.....	36
Table 4-14: J12 DSU-Serial over USB MiniAB.....	37
Table 4-15: J13 POWER – External Power Connector.....	37
Table 4-16: J14 POWER – External Power Connector.....	37
Table 4-17: SODIMM socket J15 Pin-out.....	38
Table 4-18: List and definition of Oscillators.....	39
Table 4-19: List and definition of PCB mounted LED's.....	39
Table 4-20: List and definition of Switches.....	39
Table 4-21: DIP Switch S3 'PIO[7..0]' definition.....	39
Table 4-22: DIP Switch S4 'PIO[15..8]' definition.....	40
Table 4-23: List and definition of PCB Jumpers.....	40

LIST OF FIGURES

Figure 1-1: GR-UT699 Development Board.....	8
Figure 2-1: Block Diagram of GR-UT699 board.....	11
Figure 2-2: UT699 ASIC.....	12
Figure 2-3: On-Board Memory Configuration.....	12
Figure 2-4: Block Diagram of the CAN interface.....	14
Figure 2-5: Transceiver and Termination Configuration (one of 2 interfaces shown).....	15
Figure 2-6: Transceiver and Termination of the SPW interfaces (2 of 4 interfaces shown).....	16
Figure 2-7: Serial interface.....	17
Figure 2-8: Debug Support Unit connections.....	17
Figure 2-9: Clock Distribution Scheme.....	19
Figure 2-10: Power Regulation Configuration.....	20
Figure 2-11: Block diagram of Ethernet Interface.....	21
Figure 2-12: Block diagram for PCI System Slot connections.....	22
Figure 2-13: Block diagram of PCI Peripheral connections.....	23
Figure 2-14: PIO interface.....	24
Figure 2-15: Watchdog configuration.....	25
Figure 3-1: GRMON Output Screenshot #1.....	28
Figure 3-2: GRMON Output Screenshot #2.....	29
Figure 4-1: Front Panel View (pin 1 of connectors marked).....	31
Figure 4-2: PCB Top View.....	41
Figure 4-3: GR-UT699 Assembly Photo.....	42

REVISION HISTORY

Revision	Date	Page	Description
0.1 DRAFT	2008-05-01	All	New document/draft
0.2	2008-09-16	§2.5.2 §2.12.1 19 41	Added note about SPWCLK oscillator Added notes about PCI_INT[A B C D] signals Modified Figure 2-9 Updated Figure 4-2.
0.3	2008-10-27	All	Formatting changes
0.4	2009-01-07	8,28,29, 41,42	Updated Figure 1-1, Figure 3-1, Figure 3-2, Figure 4-2, Figure 4-3



Intentionally Blank



1 INTRODUCTION

1.1 Overview

This document describes the *GR-UT699 Development Board*.

The purpose of this equipment is to provide developers with a convenient hardware platform for the evaluation and development of software for the *Aeroflex UT699RH RadHard 32-bit Fault-Tolerant LEON 3FT/SPARC™ V8 Processor ASIC* device. The *UT699* is a Leon3FT based custom ASIC for Aerospace applications.

The *GR-UT699* Unit comprises a custom designed PCB with a 6U Compact PCI front panel, making the board suitable either for stand-alone bench top development, or for installation in a 6U High Compact PCI rack. All the principle interfaces and functions are accessible on front panel connectors.

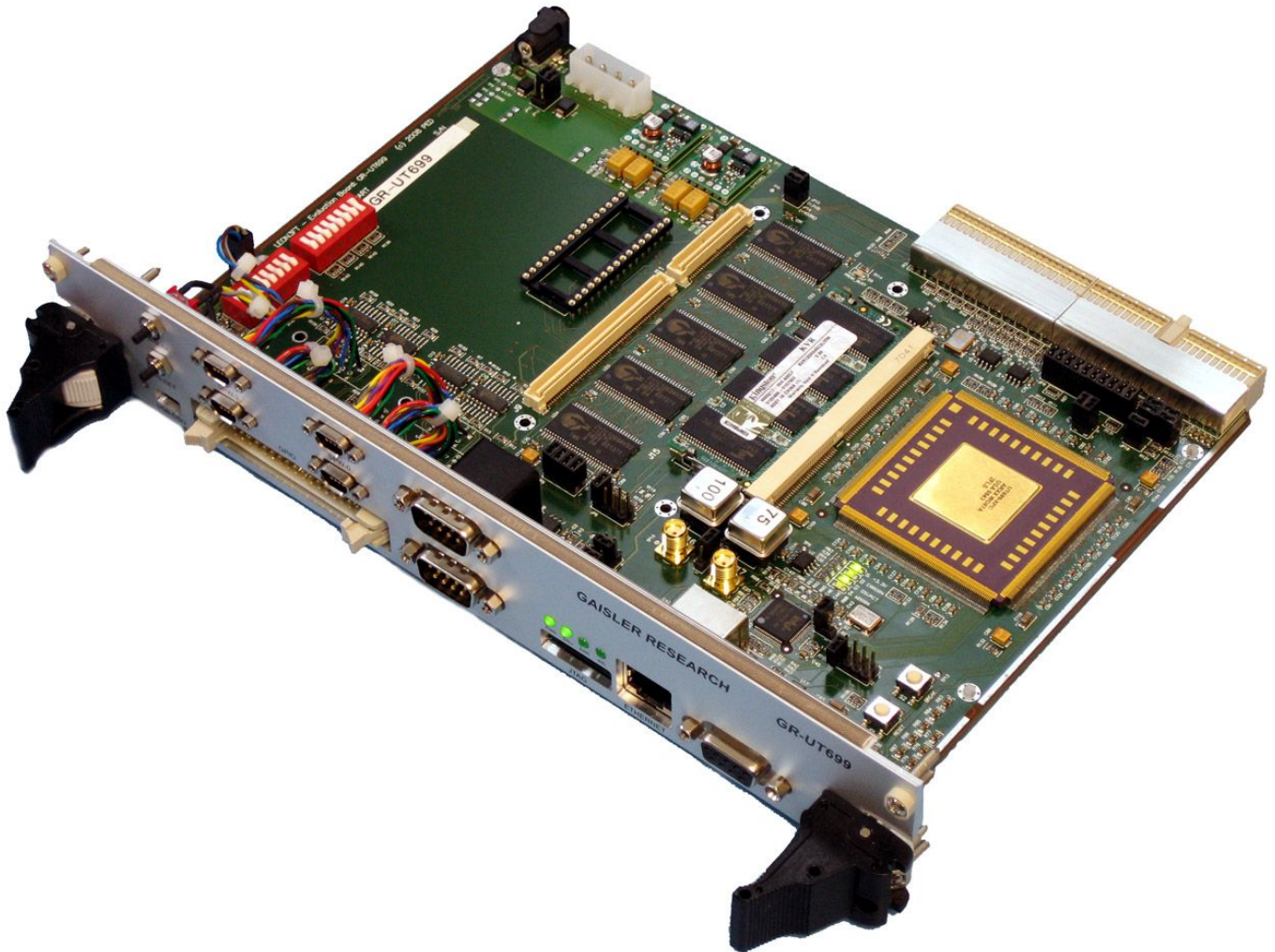

Figure 1-1: GR-UT699 Development Board

The interface connectors on the Front Panel of the unit provide:

- One Serial UART interface (RS232)
- Ethernet
- JTAG - DSU
- Two CAN bus interfaces
- Four Spacewire interfaces
- Serial DSU UART (Mini-AB USB connector)
- 16 pins General Purpose I/O Port
- Push Buttons for *RESET* and *BREAK*
- LED indicators

To enable convenient connection to the interfaces, the connector types and pin-outs are compatible with the standard connector types for these types of interfaces.

Additionally the board is equipped with a 32 bit Master/target PCI interface via standard Compact PCI Connector interface on the back edge of the PCB.

The PCB contains the following main items as detailed in section 2 of this document:

- UT699RH ASIC
- Memory
 - SRAM 80 Mbit (1 banks x 2Mword x 40 bit, typ. 10ns)
(optional second bank is not fitted as standard)
 - SDRAM SODIMM socket (up to 64Mword x 40 bit with 512Mbyte module)
 - FLASH 128Mbit (4M x 32 bit, typ. 90ns)
 - EEPROM DIL32 socket (1 bank x 1Mbit, organised x8 bit wide)
 - additional memory via memory expansion connector
- Interfaces
 - two CAN interfaces
 - four Spacewire LVDS electrical interfaces
 - one serial UART (RS232) interface
 - 10/100MBit Ethernet PHY
 - DSU - Serial (over USB Converter) interface
 - DSU - JTAG (over JTAG connector) interface
 - GPIO (16 signals) general purpose input/output port
- Power, Reset, Clock and Auxiliary circuits

1.2 References

- RD-1 GR-UT699_schematic.pdf, Schematic
- RD-2 GR-UT699_assy_drawing.pdf, Assembly Drawing
- RD-3 UT699RH Datasheet

1.3 Handling



ATTENTION : OBSERVE PRECAUTIONS FOR HANDLING ELECTROSTATIC SENSITIVE DEVICES

This unit contains sensitive electronic components which can be damaged by Electrostatic Discharges (ESD). When handling or installing the unit observe appropriate precautions and ESD safe practices.

When not in use, store the unit in an electrostatic protective container or bag.

When configuring the jumpers on the board, or connecting/disconnecting cables, ensure that the unit is in an unpowered state.

1.4 Abbreviations

DIL	Dual In-Line
ESD	Electro-Static Discharge
FP	Front Panel
FT	Fault-Tolerant
GPIO	General Purpose Input / Output
I/O	Input/Output
IP	Intellectual Property
LVDS	Low Voltage Digital Signalling
MII	Media Independent Interface
MUX	Multiplexer
PCB	Printed Circuit Board
SPW	Spacewire

2 ELECTRICAL DESIGN

2.1 Block Diagram

The *GR-UT699* board provides the electrical functions and interfaces as represented in the block diagram, Figure 2-1.

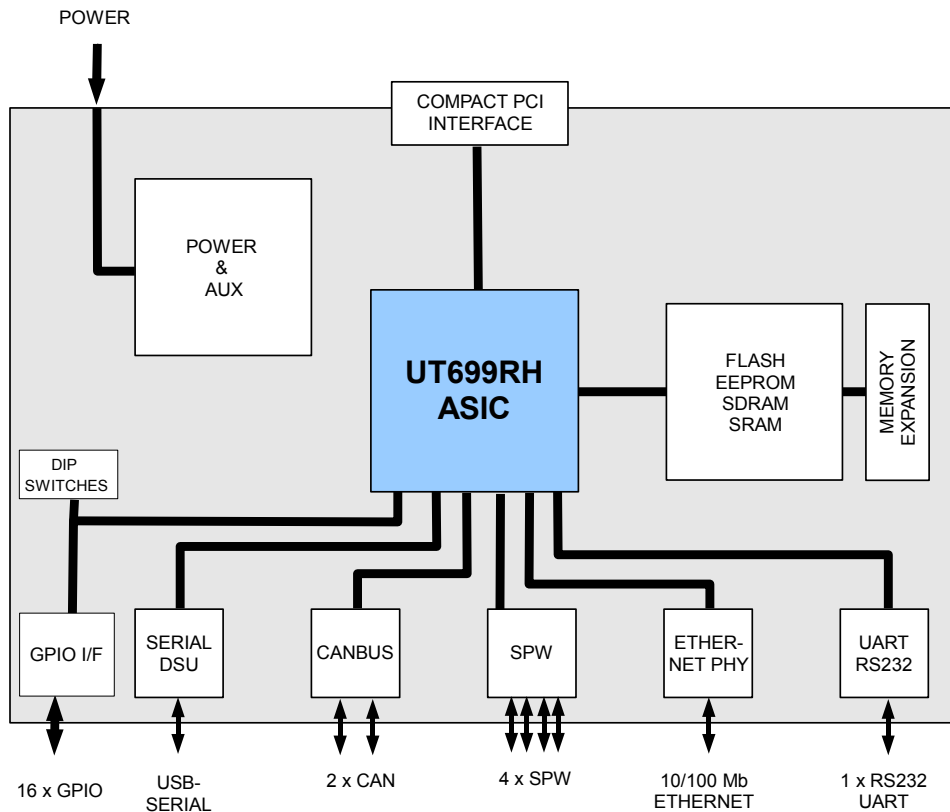

Figure 2-1: Block Diagram of GR-UT699 board

The Main PCB is of standard Double Eurocard format (233.35 x 160mm) and, in principle, could be used 'stand-alone' on the bench-top simply using an external +5V power supply. The board is fitted with a Compact PCI front panel, and is compatible with mounting in a 6U Compact PCI rack.

2.2 UT699 ASIC

The UT699RH ASCII is packaged in a 352-pin Ceramic Quad Flatpack, and is soldered in to the PCB.

Details of the interfaces, operation and programming of the UT699 ASIC is given in the *UT699 Datasheet*, RD-3.

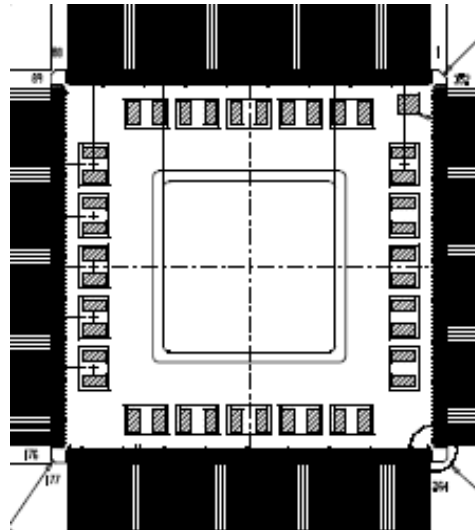

Figure 2-2: UT699 ASIC

2.3 Memory

The memory configuration installed on the board is shown in the figure below comprising of:

- 80Mbit of SRAM memory, organised as 1 banks x 2Mword x 40 bits wide (a second SRAM bank can be installed on the PCB, but is not fitted as standard)
- 128Mbit of Flash PROM, organised as 1 bank x 4 Mword x 32 bits wide)
- DIL 32 pin socket to allow 1Mbit of EEPROM organised as 1 bank x 128kByte x 8 bits wide) to be installed

Additionally, in order to allow users to install alternative memory configurations or devices, all the signals of the memory interface are connected to memory expansion connectors. The expansion connectors allow mezzanine boards to be added similar to those developed for the existing *GR-CPCI* development boards.

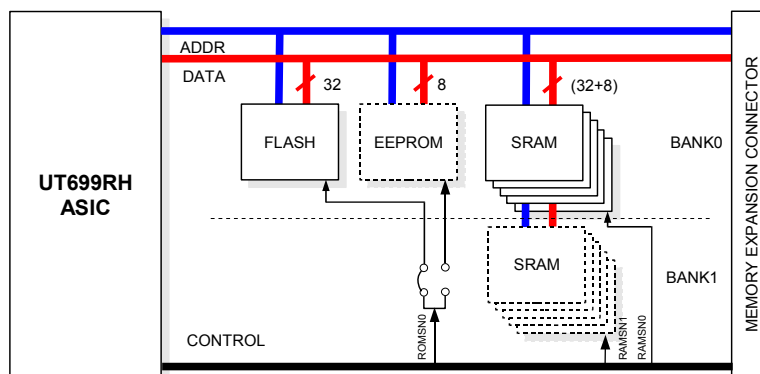

Figure 2-3: On-Board Memory Configuration

2.3.1 SRAM

The *GR-UT699* board is laid out with two SRAM memory banks but only has one bank mounted as standard. Each bank is made up of five *CY7C1069AV33*. These devices are 16Mbit (2Mbyte x 8 bit devices with 10 or 12 ns access times).

The five devices provide (32 + 8) bit wide SRAM memory paths allowing EDAC operation.

These memory banks are mapped as RAMBANK0 and RAMBANK1.

In case the user wishes to disable the on board memory, this can be done by removing the jumpers JP5 on the PCB.

2.3.2 FLASH

The *GR-UT699* board has mounted as standard one FLASH memory bank, made up of two Intel *JS28F640J3* FLASH devices. These devices are 64Mbit (8Mbyte x 16 bit devices), typically with 90ns access times. The data bus width to the Flash memory is 32 bits wide.

Note that, the PROM width and PROM EDAC conditions are set by the state of the GPIO[2..0] pins at power up of the Processor. Therefore the GPIO[2..0] DIP switches on the PCB must be appropriately set for the correct operation of the PROM memory at start up of the processor. For information on the GPIO[2..0] settings refer to the Memory Configuration documentation in the Leon3 User Manual, or RD-3.

2.3.3 EEPROM

The *GR-UT699* board additionally has a DIP32 socket suitable for mounting an EEPROM device. The data bus width to the EEPROM device is 8 bits wide.

This socket is suitable for mounting an EEPROM device of the type *AT28LV010*, or compatible, in DIP32 package. The *AT28LV010* is an ATMEL EEPROM, of 1Mbit capacity organised as 128kByte x 8 bits.

Jumpers are provided to enable the user to select either the FLASH PROM device or the EEPROM to operate as the *ROMBANK0* device which appears at the initial memory location of 0x00000000.

2.4 CAN Interface

The board provides the electrical interfaces for two CAN bus interfaces, as represented in the block diagram, Figure 2-4.

The CAN bus transceiver IC's on this board are *SN65HVD230* devices from Texas Instruments which operate from a single +3.3V power supply.

The connector interfaces are male DSUB-9 connectors adhering to the standard pin-out for this type of interface (ref. Table 4-6 And Table 4-5).

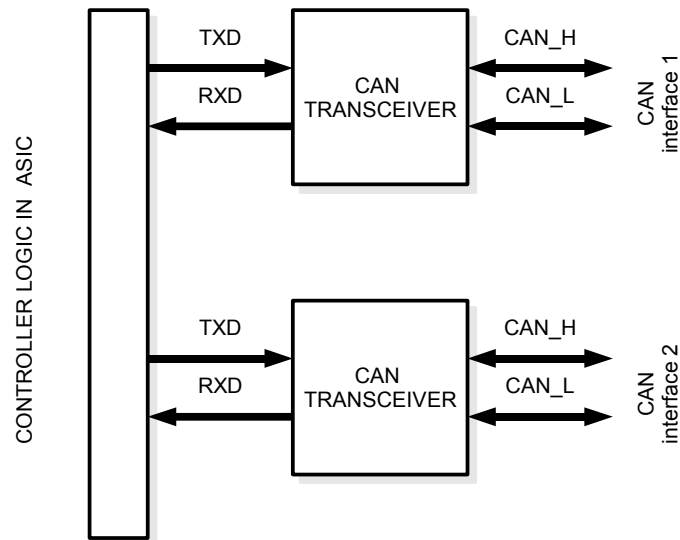

Figure 2-4: Block Diagram of the CAN interface

2.4.1 Configuration of Bus Termination

The CAN interfaces on the board can be configured for either end node or stub-node operation by means of the jumpers JP3 and JP4 for interface 1 and 2 respectively, as shown in Error: Reference source not found.

For normal end-node termination with a nominal 120 Ohm insert jumpers in position 1-3.

However, if a split termination is desired (if required for improved EMC performance), insert the jumpers in positions 1-2 and 3-4.

For stub nodes, if termination is not required, do not install any jumpers.

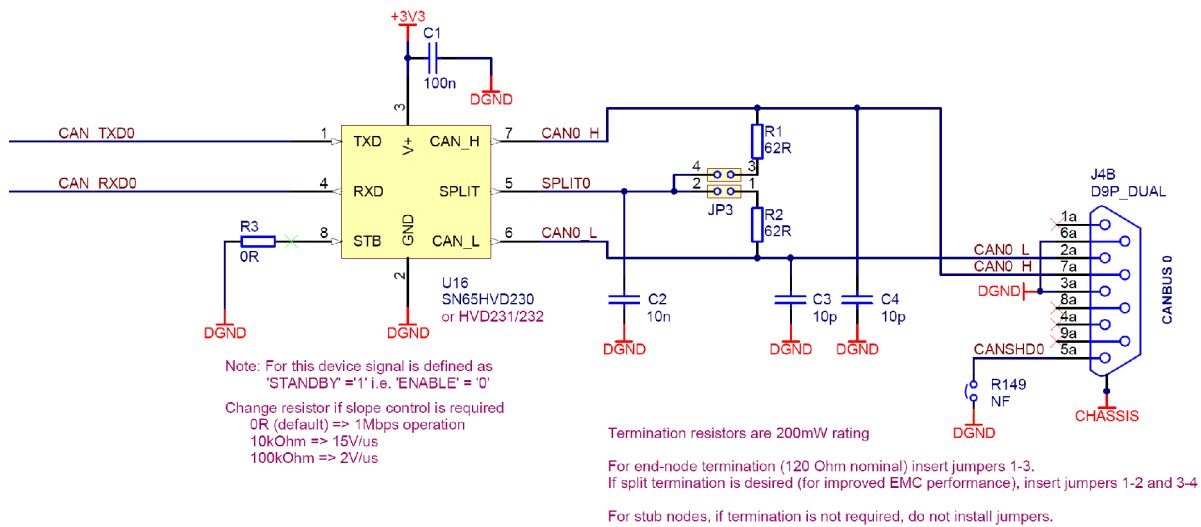

Figure 2-5: Transceiver and Termination Configuration (one of 2 interfaces shown)

2.4.2 Configuration of Slew Rate

The SN65HVD230 transceiver device used on the board has the facility to set the device into *STANDBY* mode, by connecting an active high external signal to pin 8 of the device (refer to Error: Reference source not found). However, on this board this is tied to permanently 'low' to enable the CAN bus Transceivers.

A further feature provided by the SN65HVD230 device is the capability to adjust the transceiver slew rate. This can be done by modifying the values of resistors connected to pin 8 of the transceivers.

The default value of 0 ohms is compatible with 1Mbps operation.

From the data sheet the following resistor values give the following slew rates:

10kOhm => 15V/us

100kOhm => 2V/us

2.5 Spacewire (LVDS) Interfaces

The *UT699* ASIC provides four Spacewire interfaces which are routed to the front panel of the board.

2.5.1 SPW interface circuit

Each Spacewire interface consists of 4 LVDS differential pairs (2 input pairs and 2 output pairs), as shown in the figure below. As the Spacewire interface to the *UT699* ASIC is LVTTTL (3.3V logic), LVDS driver and receiver circuits are required on the PCB to interface between the ASIC and the external interface.

The PCB traces for the LVDS signals on the *GR-UT699* board are laid out with 100-Ohm differential impedance design rules and matched trace lengths.

100 Ohm Termination resistors for the LVDS receiver signals are mounted on the board close to the receiver.

The pin out and connector types for these Spacewire interfaces conform to the Spacewire standard, as shown in Figure 2-6.

The inner shield pin (pin3 of the connector) is connected to DGND via a Zero-ohm resistor.

2.5.2 SPWCLK

Configuration options on the board (jumpers, crystal socket and SMA coaxial connector) allow this Spacewire clock to be provided from the following sources:

- Dedicated *SPWCLK* oscillator (if appropriate Oscillator X3 is mounted in socket and jumper J17 is not installed)
- Main processor oscillator X1 (if jumper J17 is installed)
- External clock input via SMA connector J16. (X3 and J17 not installed)

The default configuration is that the clock is supplied by the SPWCLK oscillator X3, and

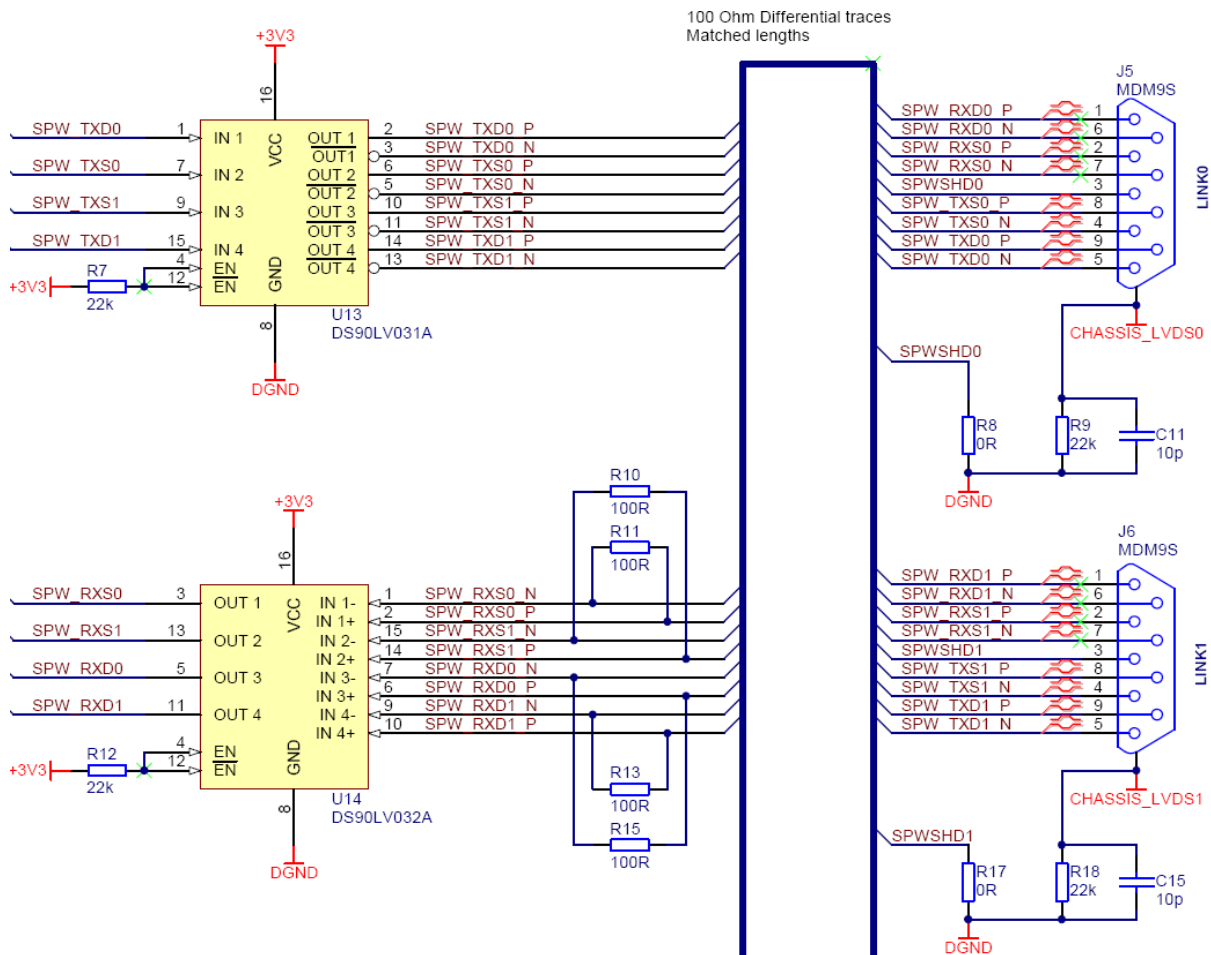

Figure 2-6: Transceiver and Termination of the SPW interfaces (2 of 4 interfaces shown)

jumper J17 is not installed. Do not install jumper J17 if an oscillator is installed in X3 socket as this will unintentionally connect the outputs of oscillator X1 and Oscillator X3 together.

2.6 Serial Interface

The *UT699RH* ASIC, provides a single Serial port, with TXD/RXD pins, and the *GR-UT699* board provides an RS232 driver/receiver chip and routes these signals to a front panel connector.

The front panel connector type for the UART interface is Female D-Sub 9 pin type with a standard pin-out for serial links.

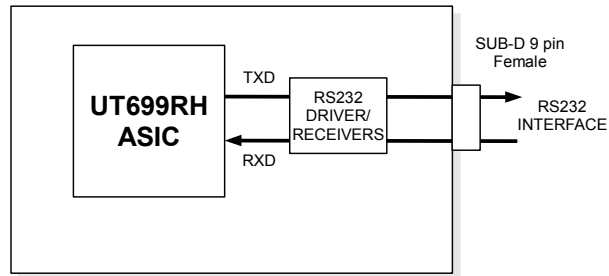

Figure 2-7: Serial interface

2.7 Debug Support Unit (DSU) Serial Interface

The *GR-UT699* unit provides a interface for Debug and control of the processor by means of a host terminal via the DSU serial link to the *UT699* ASIC, as represented in Figure 2-8.

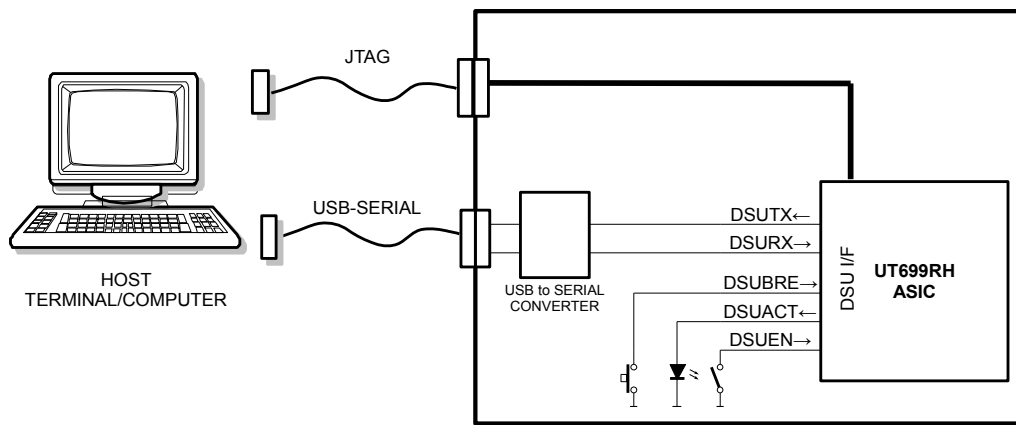

Figure 2-8: Debug Support Unit connections

The board provides two possibilities for connecting to the processor's DSU interface:

1. USB MiniAB connector with USB to Serial interface chip
2. JTAG DSU interface

The baud rate of the serial link is specified by the host computer, and the DSU interface in the *UT699* ASIC auto-detects and adjusts its baud rate to suit.

The *DSUENable* signal input to the processor is connected to a jumper on the PCB. In normal use the DSU feature will always be enabled to allow processor control and program debugging via the DSU link.

An LED is provided on the PCB to indicate the conditions of the *DSUACT* signal from the *UT699* processor. Additionally connections are provided to an LED indicator on the front panel of the Unit.

A miniature push button switch is provided on the Main PCB for the *DSUBREAK* control, and connections are provided to an additional push-button switch on the front panel of the unit.

2.8 Oscillators and Clock Inputs

The oscillator and clock scheme for the UT699 ASIC is shown in Figure 2-9.

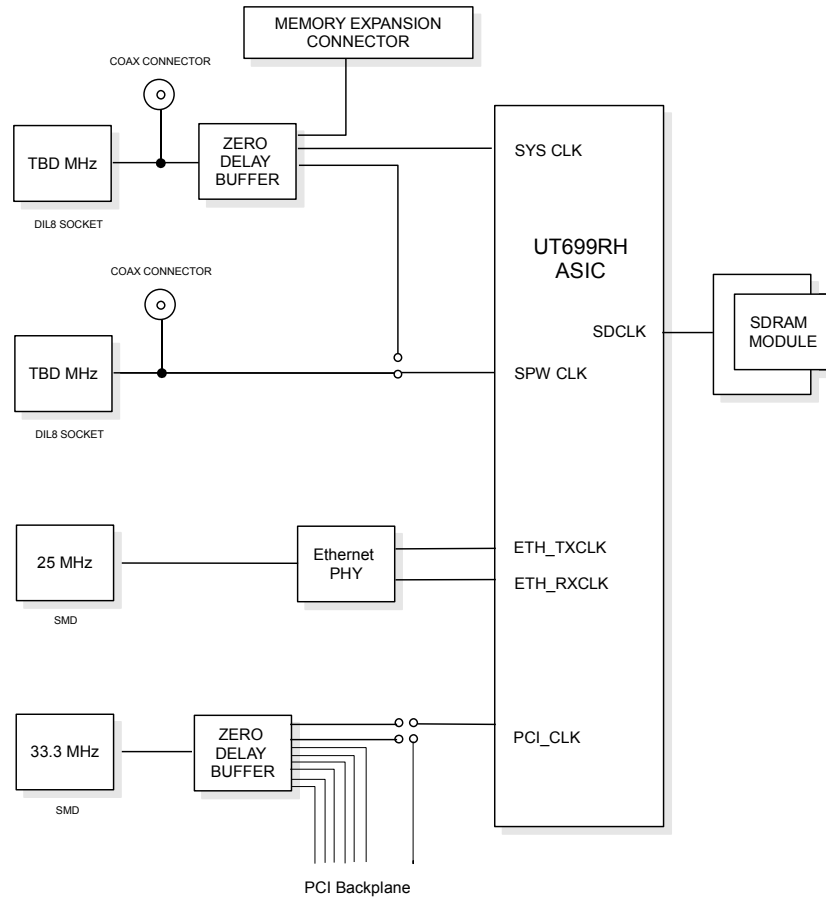

Figure 2-9: Clock Distribution Scheme

2.8.1 System Clock

The main oscillator for the *UT699* ASIC is a 75 MHz Crystal oscillator. This oscillator will be a 4 pin DIL8 style oscillator, installed in a socket on the board. A zero-delay buffer circuit (CY2305) is used to distribute the SYSCLK.

2.8.2 SPW_CLK

The *SPWCLK* can be derived from either the SYSCLK, a separate socketed on-board crystal oscillator, or can be injected on a coaxial connector on the board.

2.8.3 Ethernet Clock

A dedicated 25MHz SMD oscillator is provided for the Ethernet Controller and PHY circuit (see section 2.10).

2.8.4 PCI Clock

A dedicated 33.3MHz SMD oscillator and zero delay buffer are provided for the PCI clock.

For information on the configuration, please see section 2.11.

2.9 Power Supply and Voltage Regulation

The board operates from a single +5V DC power supply input. On board regulators generate the following voltages:

- +3.3V for the UT699 I/O voltage, memory chip and other peripherals
- +2.5V for UT699 Vcore voltage

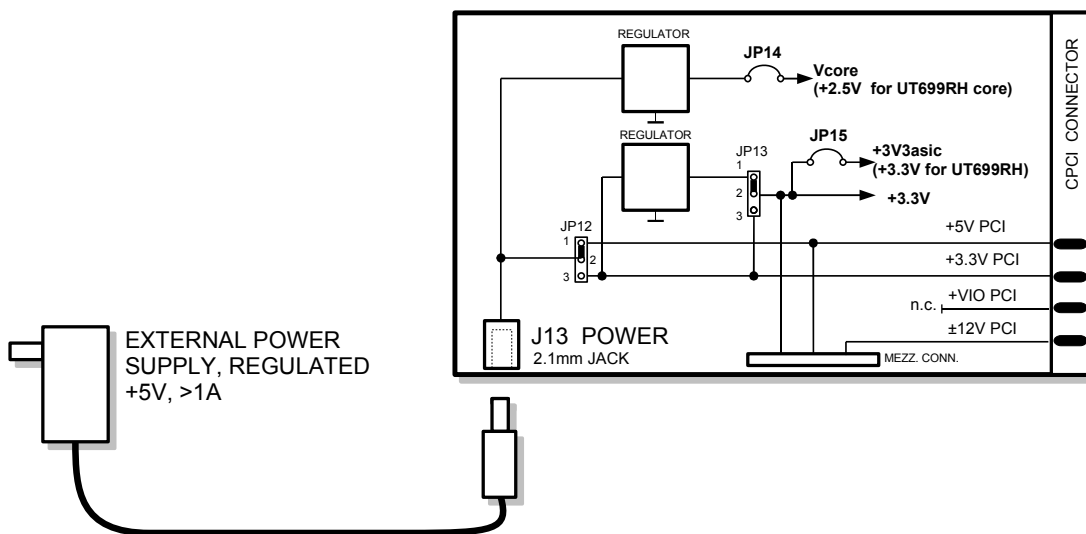

Figure 2-10: Power Regulation Configuration

All voltages +5V, +3.3V, ±12V are provided via the memory expansion connector interface making feasible that user defined mezzanine boards can use these voltages.

If the Board is installed in a Compact PCI rack, the board can be configured by means of jumpers such that the +5V, +3.3V, +12V and -12V are provided from the Compact PCI backplane instead of the internal regulators.

2.10 Ethernet Interface

The *UT699RH* ASIC device incorporates a Ethernet controller with support for MII interface, and the *GR-UT699* Development Board has an Intel LXT971 10/100Mbit/s Ethernet PHY transceiver and RJ45 connector are on board.

For more information on the registers and functionality of the Ethernet MAC+PHY device please refer to the data sheet for the *WJLXT971A* device.

A 25MHz oscillator dedicated for this device is provided on the board.

The interrupt output of the Ethernet MDIO interface is connected to the *PIO[4]* input to the *UT699* ASIC. This can be disabled by removing jumper *JP2* if necessary.

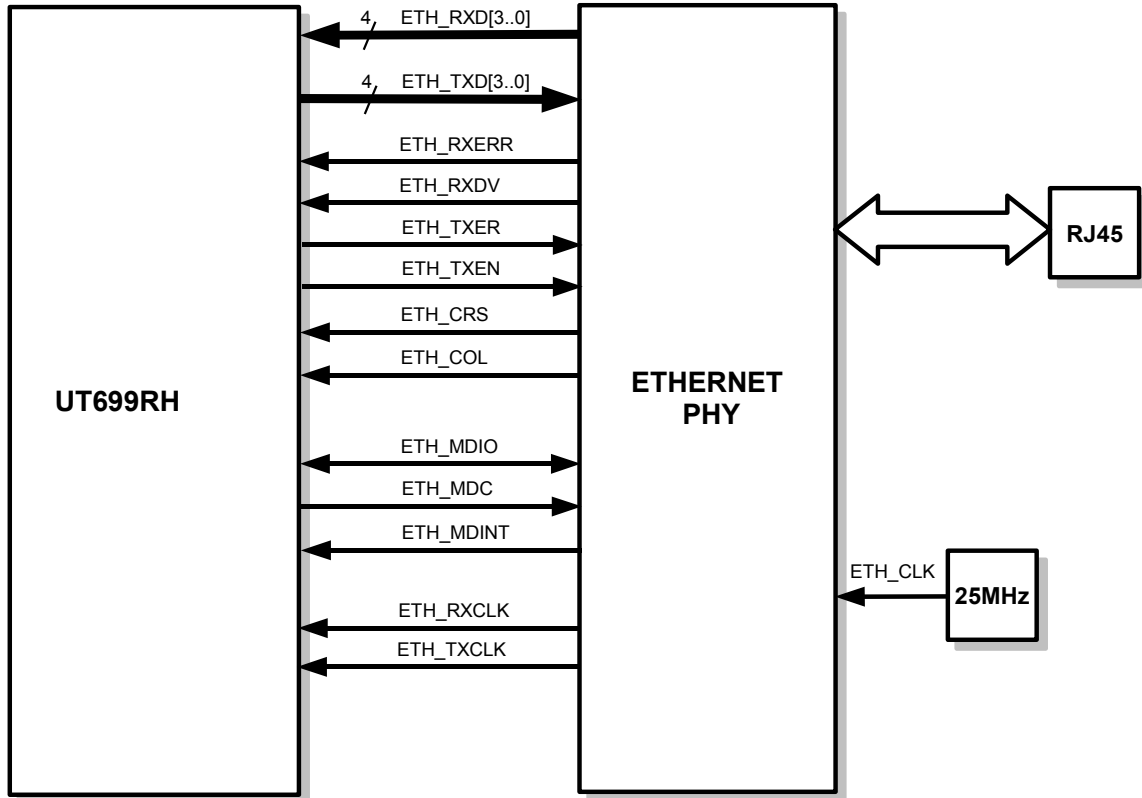

Figure 2-11: Block diagram of Ethernet Interface

2.11 PCI Interface

The *UT699RH* ASIC incorporates a 33MHz/32 bit interface with 8 channel PCI Arbiter and is capable of being configured to be installed in either the SYSTEM slot (HOST) or in PERIPHERAL slots (GUEST).

The *GR-UT699* board can be configured to operate either as a peripheral slot card or system slot card as described in the following sections.

Note that the *GR-UT699* board has been designed to operate in a 3.3V signalling environment, and the Compact PCI connector is appropriately keyed (yellow key).

2.11.1 Host/System Slot Configuration

When installed in the System slot, the board provides the PCI arbitration and distributes the required PCI clocks to the backplane, and to the PCI interface in the FPGA.

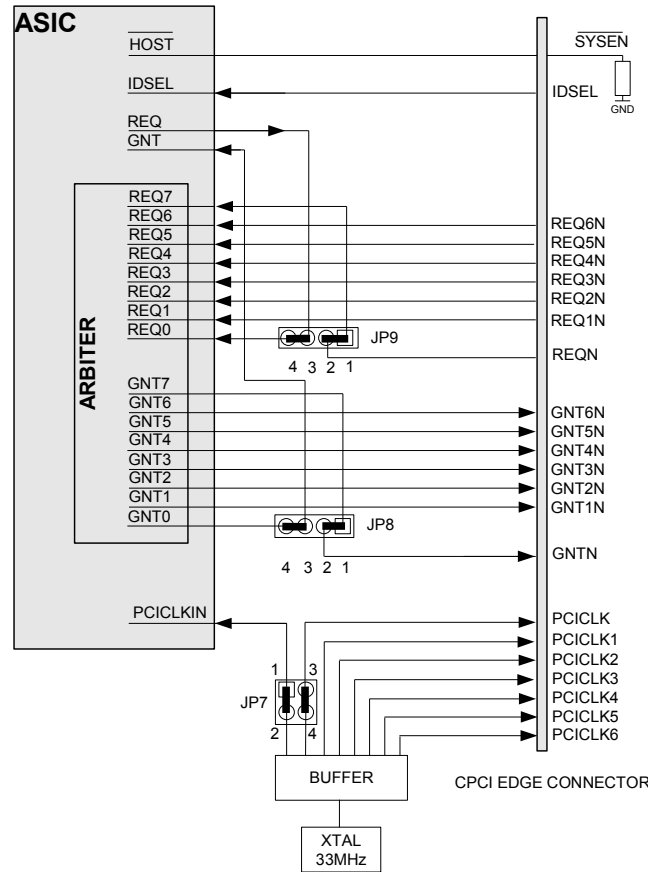

Figure 2-12: Block diagram for PCI System Slot connections

This requires the jumpers to be installed as follows:

JP7	1-2 and 3-4
JP8	1-2 and 3-4
JP9	1-2 and 3-4

Additionally, the PCI specification requires that the following system signals are pulled-up by the card operating in the system slot:

- PCI_FRAMEN PCI_IRDYN
- PCI_TRDYN PCI_DEVSELN
- PCI_STOPN PCI_PERRN
- PCI_SERRN PCI_LOCKN

This can be achieved by installing the JP8 jumpers 1-2, 3-4, 5-6, 7-8, 9-10, 11-12, 13-14, 15-16, 17-18 and 19-20.

In order to ensure that the PCIRSTN pin on the back plane is not left floating, it is also necessary to ensure that this pin is driven by the host slot. This can be achieved by installing jumper JP18 on the board, so that the board system reset signal RESETN provides the drive for the PCIRSTN signal. If the jumper is not installed, a weak (22k) pull up will pull the PCIRSTN signal high.

2.11.2 Peripheral Slot Configuration

When functioning in a Peripheral slot, the board receives its input clock from the backplane, and connects its REQN/GNTN signals to the backplane REQN/GNTN signals.

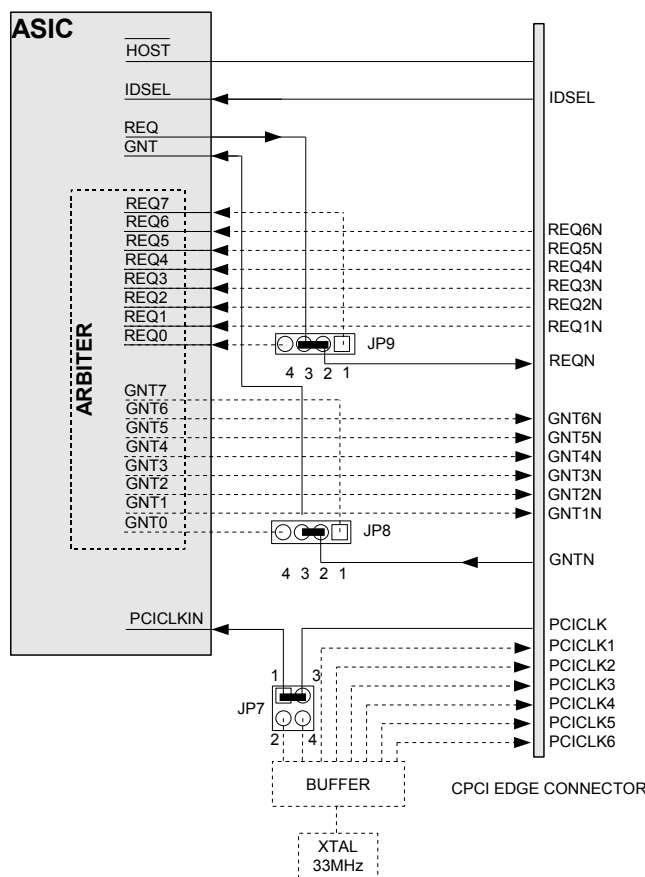

Figure 2-13: Block diagram of PCI Peripheral connections

This requires the jumpers to be installed as follows:

JP7	1-3
JP8	2-3
JP9	2-3

All the jumpers in JP8 and JP18 should be not be installed.

2.12 Other Interfaces and Circuits

2.12.1 GPIO

The 16 general Purpose Input Output signals of the ASIC (3.3V LVTTTL voltage levels) are connected to a set of 0.1" pitch pin header connector on the front panel thus allowing easy access to these signals. A series protection resistor of 470 Ohm is included on each signal at the front panel connector.

Weak pull ups (47k) are provided on each of the signals lines on the PCB and additionally a set of DIP Switches allow the user convenient programming of the signal state when the GPIO lines are configured as inputs. When programmed as outputs the DIP switches should be left in the 'open' state.

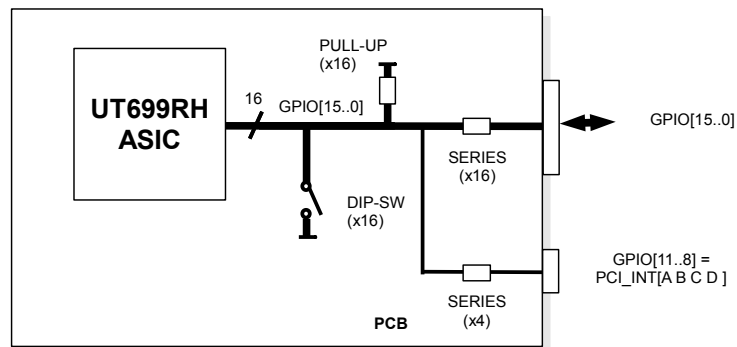

Figure 2-14: PIO interface

Note that the GPIO[11..8] signals are also connected to the PCI Interrupt pins PCI_INT[A B C D] on the PCI connector PCI-J1 via a 33R series resistor. This is intended in order to allow the GPIO signals to generate or receive PCI interrupts from the backplane if desired.

If the board is installed in a CPCI rack, setting/resetting the GPIO[11..8] may therefore cause unintended behaviour, by generating a generating PCI Interrupts on the back plane.

If this behaviour is not desired, disconnect the GPIO signals from the PCI interrupts on the back plane by removing resistor pack R35.

2.12.2 Reset Circuit and Button

A standard Processor Power Supervisory circuit (TPS3705 or equivalent) is provided on the Board to provide monitoring of the 3.3V power supply rail and to generate a clean reset signal at power up of the Unit.

To provide a manual reset of the board, a miniature push button switch is provided on the Main PCB for the control. Additionally connections are provided to an additional push-button *RESET* switch on the front panel of the unit.

2.12.3 Watchdog

The *UT699* ASIC includes a Watchdog timer function which can be used for the purpose of generating a system reset in the event of a software malfunction or crash.

On this development board the *WDOGN* signal is connected as shown in the Figure 2-15 to the Processor Supervisory circuit.

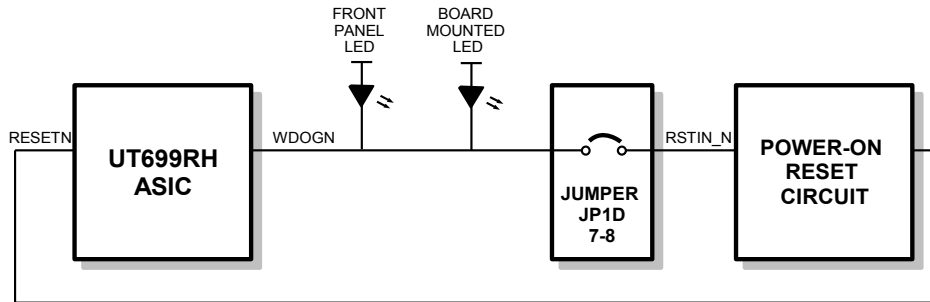

Figure 2-15: Watchdog configuration

To utilise the Watchdog feature, it is necessary to appropriately set-up and enable the Watchdog timer. Please consult the *UT699* data sheet (RD-3) for the correct register locations and details.

Also, to allow the *WDOGN* signal to generate a system reset it is necessary to install the Jumper JP1 pins 7-8 (see Figure 2-15).

For software development it is often convenient or necessary to disable the Watchdog triggering in order to be able to easily debug without interference from the Watchdog operation. In this case, the Jumper JP1 7-8 should be in the *removed*. When the watchdog triggers, the Watchdog LED's will illuminate, but a system reset will not occur.

2.12.4 JTAG interface

A 14 pin connector on the front panel provides the possibility to connect to the JTAG signals and JTAG chain of the *UT699* ASIC.

This interface allows DSU Debug over the JTAG interface to be performed.

3 SETTING UP AND USING THE BOARD

The default status of the Jumpers on the boards is as shown in table Figure 3-1.

In this configuration the board is set up as a PCI Host. For the meaning of the various jumpers, refer to Table 4-23 and RD 1.

Jumper	Jumper Setting	Comment
JP1	1-2 not installed 3-4 not installed 5-6 not installed 7-8 installed	ASIC TEST mode pin not enabled DSU is enabled JTAG interface is enabled Watchdog output can cause board reset
JP2	Not installed	Ethernet MDIO interface interrupt is not connected to GPIO4
JP3	Install 1-3	End-stub termination enabled – see section 2.4.1
JP4	Install 1-3	End-stub termination enabled – see section 2.4.1
JP5	Install 1-2, 3-4, 5-6, 7-8	Connects RAMSN0 and RAMSN1 to on board SRAM banks
JP6	Install 1-2	Connects ROMSN0 to on board Flash Prom
JP7	Install 1-2 and 3-4	PCI Host Mode clocks to backplane – see section 2.11
JP8	Install 1-2, 3-4, 5-6, 7-8, 9-10, 11-12, 13-14, 15-16, 17-18, 19-20	PCI Host Mode- Pull ups enabled – see section 2.11
JP9	Install 1-2 and 3-4	PCI Host Mode – see section 2.11
JP10	Install 1-2 and 3-4	PCI Host Mode – see section 2.11
JP11	Installed	Connects to Front Panel LED indicators
JP12	Installed 1-2	See section 2.9
JP13	Installed 1-2	See section 2.9
JP14	Installed	Can be used as current measure point for Vcore supply to ASIC
JP15	Installed	Can be used as current measure point for 3.3V supply to ASIC
JP16	Installed	Connected to Front Panel push buttons for RESET and BREAK
JP17	Not installed	Oscillator X3 provides source for SPW_CLK
JP18	Installed 1-2	Board RESETN also generated PCI_RSTN for PCI Host

Table 3-1: Default Status of Jumpers/Switches

To operate the unit stand alone on the bench top, connect the +5V power supply to the Power Socket at the back of the unit.

The front-panel POWER LED should be illuminated indicating that the +3.3V power is active.

Upon power on, the Processor will start executing instructions beginning at the memory location 0x00000000, which is the start of the PROM. If the PROM is 'empty' or no valid program is installed, the first executed instruction will be invalid, and the processor will halt with an ERROR condition, with the ERROR LED illuminated.

Pressing the DSU-BREAK button should illuminate the DSUACT LED and halt the processor.

To perform software download and debugging on the processor, a link from the Host computer to the DSU interface of the board is necessary. A connection to the DSU of the board can be made using a USB cable (Type-A to Mini-AB connectors) from the Host PC to the USB-DSU connector on the front panel.

Note, to use the USB-DSU interface you need to install the FTDI Virtual Com driver on the Host PC. This driver allows the USB connection to the board to be used as a 'virtual' serial port, operating at baud rates up to 460800 Baud.

These drivers can be downloaded from the *FTDI* web site, (www.ftdichip.com/FTDrivers.htm) and drivers for both Linux and Windows are available. Information for the installation of these drivers can be found on the *FTDI* web site

To perform program download and software debugging on the hardware it is necessary to use the Gaisler Research *GRMON* debugging software, installed on a host PC (as represented in Figure 2-8).

Note that it is necessary to use the 'PRO' version of *GRMON*, as the *UT699* ASIC incorporates FT features. It is not possible to use evaluation version of *GRMON* with this ASIC. Please refer to the *GRMON* documentation for the installation of the software on the host PC (Linux or Windows), and for the installation of the associated hardware dongle.

Starting *GRMON*, with the command:

```
grmon -i
```

will establish a link to the DSU, and will initialise the processor registers and timers.

The default serial interface used by *GRMON* is */dev/ttyS0* (linux) or *com1* (Windows).

To use a different serial interface, specify the command

```
grmon -i -uart /dev/comXX
```

where *XX* is the number of the com port.

In the example shown in Figure 3-1 a connection is being made with *GRMON* over the USB-Serial link, which in this instance is *com63* on the host (Windows) PC.

Alternatively to connect via the *JTAG_DSU* interface start *GRMON*, with the command:

```
grmon -i -jtag -freq 75
```

(Where '75' is the clock frequency of the main processor oscillator).

The resulting response generated on the Host Computer is shown in Figure 3-1.

Typing the command *flash* will reported the detected Flash Prom memory configuration and *info sys* will provide more information on the processors registers and internal cores as shown in Figure 3-2.

Program download and debugging can be performed in the usual manner. More information on the usage, commands and debugging features of *GRMON*, is given in the *GRMON Users Manual* and associated documentation.

```

Administrator@dieseldong ~
$ grmon-pro-1.1.31/win32/grmon.exe -i -u -uart /dev/com63 -edac

GRMON LEON debug monitor v1.1.31

Copyright (C) 2004-2008 Gaisler Research - all rights reserved.
For latest updates, go to http://www.gaisler.com/
Comments or bug-reports to support@gaisler.com

try open device ///com63
###opened device ///com63

Device ID: : 0x699
GRLIB build version: 2564

initialising .....
detected frequency: 75 MHz

Component                               Vendor
LEON3FT SPARC U8 Processor               Gaisler Research
AHB Debug UART                           Gaisler Research
AHB Debug JTAG TAP                       Gaisler Research
Fast 32-bit PCI Bridge                   Gaisler Research
PCI/AHB DMA controller                   Gaisler Research
GR Ethernet MAC                           Gaisler Research
GRSPW Spacewire Link                     Gaisler Research
GRSPW Spacewire Link                     Gaisler Research
GRSPW Spacewire Link                     Gaisler Research
GRSPW Spacewire Link                     Gaisler Research
FT Memory Controller                     Gaisler Research
AHB/APB Bridge                           Gaisler Research
LEON3 Debug Support Unit                  Gaisler Research
OC CAN controller                         Gaisler Research
Generic APB UART                          Gaisler Research
Multi-processor Interrupt Ctrl            Gaisler Research
Modular Timer Unit                       Gaisler Research
Unknown device                           Gaisler Research
PCI Arbiter                              European Space Agency
General purpose I/O port                  Gaisler Research
AHB status register                       Gaisler Research

Use command 'info sys' to print a detailed report of attached cores
grlib> flash

Intel-style 32-bit <2x16-bit> flash

Manuf.   Intel           Intel
Type     MT28F640J3          MT28F640J3

Device ID 775b462201a8120e  7a90462201a81205
User ID  ffffffff          ffffffff

2 x 8 Mbyte = 16 Mbyte total @ 0x00000000

CFI information

flash family : 1
flash size   : 64 Mbit
erase regions: 1
erase blocks : 64
write buffer : 32 bytes
region 0     : 64 blocks of 128 Kbytes

grlib> info sys
00.01:053 Gaisler Research LEON3FT SPARC U8 Processor (ver 0x0)
          ahb master 0
01.01:007 Gaisler Research AHB Debug UART (ver 0x0)
          ahb master 1
          apb: 80000700 - 80000800
          baud rate 115200, ahb frequency 75.00
02.01:01c Gaisler Research AHB Debug JTAG TAP (ver 0x0)
          ahb master 2
03.01:014 Gaisler Research Fast 32-bit PCI Bridge (ver 0x0)
          ahb master 3, irq 3
          ahb: c0000000 - 00000000
          ahb: ff000000 - fff20000
          apb: 80000400 - 80000500
04.01:016 Gaisler Research PCI/AHB DMA controller (ver 0x0)
          ahb master 4

```

Figure 3-1: GRMON Output Screenshot #1

```

04.01:016  Gaisler Research PCI/AHB DMA controller (ver 0x0)
            ahb master 4
            apb: 80000500 - 80000600
05.01:01d  Gaisler Research GR Ethernet MAC (ver 0x0)
            ahb master 5, irq 14
            apb: 80000e00 - 80000f00
06.01:01f  Gaisler Research GRSPW Spacewire Link (ver 0x0)
            ahb master 6, irq 10
            apb: 80000a00 - 80000b00
07.01:01f  Gaisler Research GRSPW Spacewire Link (ver 0x0)
            ahb master 7, irq 11
            apb: 80000b00 - 80000c00
08.01:01f  Gaisler Research GRSPW Spacewire Link (ver 0x0)
            ahb master 8, irq 12
            apb: 80000c00 - 80000d00
09.01:01f  Gaisler Research GRSPW Spacewire Link (ver 0x0)
            ahb master 9, irq 13
            apb: 80000d00 - 80000e00
00.01:054  Gaisler Research FT Memory Controller (ver 0x1)
            ahb: 00000000 - 20000000
            ahb: 20000000 - 40000000
            ahb: 40000000 - 80000000
            apb: 80000000 - 80000100
            32-bit prom @ 0x00000000
            32-bit static ram: 1 * 8192 kbyte @ 0x40000000
            32-bit sdram: 1 * 128 Mbyte @ 0x60000000, col 10, cas 2, ref 7.8 us

01.01:006  Gaisler Research AHB/APB Bridge (ver 0x0)
            ahb: 80000000 - 80100000
02.01:004  Gaisler Research LEON3 Debug Support Unit (ver 0x1)
            ahb: 90000000 - a0000000
            AHB trace 128 lines, stack pointer 0x407ffff0
            CPU#0 win 8, hwbp 4, itrace 128, U8 mul/div, srmmu, lddel 2, GRFPU
            icache 2 * 4 kbyte, 32 byte/line lru
            dcache 2 * 4 kbyte, 16 byte/line lru
06.01:019  Gaisler Research OC CAN controller (ver 0x1)
            irq 4
            ahb: fff20000 - fff21000
            cores: 2
01.01:00c  Gaisler Research Generic APB UART (ver 0x1)
            irq 2
            apb: 80000100 - 80000200
            baud rate 38422, DSU mode <loop-back>
02.01:00d  Gaisler Research Multi-processor Interrupt Ctrl (ver 0x3)
            apb: 80000200 - 80000300
03.01:011  Gaisler Research Modular Timer Unit (ver 0x0)
            irq 6
            apb: 80000300 - 80000400
            12-bit scaler, 4 * 32-bit timers, divisor 75
06.01:02c  Gaisler Research Unknown device (ver 0x0)
            apb: 80000600 - 80000700
08.04:010  European Space Agency PCI Arbiter (ver 0x0)
            apb: 80000800 - 80000900
09.01:01a  Gaisler Research General purpose I/O port (ver 0x0)
            apb: 80000900 - 80000a00
0f.01:052  Gaisler Research AHB status register (ver 0x0)
            irq 1
            apb: 80000f00 - 80001000

grib> wash
clearing 8192 kbyte SRAM: 40000000 - 40800000
clearing 131072 kbyte SDRAM: 60000000 - 68000000
grib> load gr-test/leon3/samples/stanford
section: .text at 0x40000000, size 54288 bytes
section: .data at 0x4000d410, size 2080 bytes
total size: 56368 bytes <29.5 kbit/s>
read 278 symbols
entry point: 0x40000000
grib> run
Starting
  Perm Towers Queens Intmm Mm Puzzle Quick Bubble Tree FFT
    17    33    33    50   600   183    16    33   134   634

Nonfloating point composite is          75
Floating point composite is           532
Program exited normally.

```

Figure 3-2: GRMON Output Screenshot #2

4 INTERFACES AND CONFIGURATION

4.1 List of Front/Back Panel Connectors

Name	Function	Type	Description
J1	UART-1	D9-S (Female)	Connections for Serial UART-1 (RS232)
J2	ETHERNET	RJ45	10/100Mbit/s Ethernet Connector
J3	JTAG	2x7pin 2mm header	JTAG signal interface
J4A upper	CANBUS-1	Dual D9-P (male)	Connections for CANBUS-1 interface
J4B lower	CANBUS-0	Dual D9-P (male)	Connections for CANBUS-0 interface
J5	SPW-0	MDM9-S (female)	LVDS connections for Spacewire Interface-0
J6	SPW-1	MDM9-S (female)	LVDS connections for Spacewire Interface-1
J7	SPW-2	MDM9-S (female)	LVDS connections for Spacewire Interface-2
J8	SPW-3	MDM9-S (female)	LVDS connections for Spacewire Interface-3
J9	MEM I/O	AMP 5177984-5	Memory I/O connector -120 pin 0.8mm pitch
J10	GPIO[15..0]	34 pin 0.1" Header	Pin connections for PIO signals 0 to 15
J11	GEN I/O	AMP 5177984-2	General I/O connector – 80 pin 0.8mm pitch
J12	DSU-SERIAL	USB-MINI-AB	Debug Support Unit serial I/F via on-board USB converter
J13	POWER-IN	2.1mm center +ve	+5V DC power input connector
J14	POWER-IN'	Mate-N-Lok 4pin	Alternative power input for 4 pin IDE style connector
J15	SDRAM	SODIMM	SDRAM memory interface for SODIMM module
J16	SPW_CLK	SMA	SPW Clock Monitor or Injection
J17	PROC_CLK	SMA	Processor Clock Monitor or Injection
CPCI-J1	CPCI	CPCI Type A	CPCI connector
CPCI-J2	CPCI	CPCI Type B	CPCI connector

Table 4-1: List of Connectors

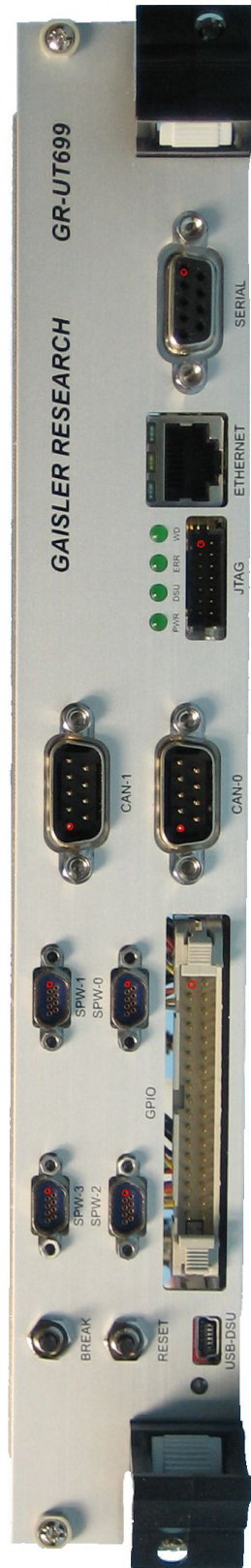

Figure 4-1: Front Panel View (pin 1 of connectors marked)

Pin	Name	Comment
1		No connect
6		No connect
2	TXD-1	Transmit pin
7		No connect
3	RXD-1	Receive pin
8		No connect
4		No connect
9		No connect
5	GND	Ground

Table 4-2: J1 UART-1 - Serial Interface (RS232) connections

Pin	Name	Comment
1	TPFOP	Output +ve
2	TPFON	Output -ve
3	TPFIP	Input +ve
4	TPFOC	Output centre-tap
5		No connect
6	TPFIN	Input -ve
7	TPFIC	Input centre-tap
8		No connect

Table 4-3: J2 RJ45-ETHERNET Connector

Pin	Name	Comment
1	DGND	Ground
2	VREF	3.3V
3	DGND	Ground
4	TMS	JTAG: TMS
5	DGND	Ground
6	TCK	JTAG: TCK
7	DGND	Ground
8	TDO	JTAG: TDO
9	DGND	Ground
10	TDI	JTAG: TDI
11	DGND	Ground
12	NC	No connect
13	DGND	Ground
14	NC	No connect

Table 4-4: J3 ASIC- JTAG Connector

Pin	Name	Comment
1		No connect
6	GND	Ground
2	CAN1_L	CAN Dominant Low
7	CAN1_H	CAN Dominant High
3	GND	Ground
8		No connect
4		No connect
9		No connect
5	CANSHD1	Shield

Table 4-5: J4A (upper connector) CANBUS-1 interface connections

Pin	Name	Comment
1		No connect
6	DGND	Ground
2	CAN0_L	CAN Dominant Low
7	CAN0_H	CAN Dominant High
3	DGND	Ground
8		No connect
4		No connect
9		No connect
5	CANSHD0	Shield

Table 4-6: J4B (lower connector) CANBUS-0 interface connections

Pin	Name	Comment
1	DIN0+	Data In +ve
6	DIN0-	Data In -ve
2	SIN0+	Strobe In +ve
7	SIN0-	Strobe In -ve
3	SHIELD	Inner Shield
8	SOUT0+	Strobe Out +ve
4	SOUT0-	Strobe Out -ve
9	DOUT0+	Data Out +ve
5	DOUT0-	Data Out -ve

Table 4-7: J5 SPW-0 interface connections

Pin	Name	Comment
1	DIN1+	Data In +ve
6	DIN1-	Data In -ve
2	SIN1+	Strobe In +ve
7	SIN1-	Strobe In -ve
3	SHIELD	Inner Shield
8	SOUT1+	Strobe Out +ve
4	SOUT1-	Strobe Out -ve
9	DOUT1+	Data Out +ve
5	DOUT1-	Data Out -ve

Table 4-8: J6 SPW-1 interface connections

Pin	Name	Comment
1	DIN2+	Data In +ve
6	DIN2-	Data In -ve
2	SIN2+	Strobe In +ve
7	SIN2-	Strobe In -ve
3	SHIELD	Inner Shield
8	SOUT2+	Strobe Out +ve
4	SOUT2-	Strobe Out -ve
9	DOUT2+	Data Out +ve
5	DOUT2-	Data Out -ve

Table 4-9: J7 SPW-2 interface connections

Pin	Name	Comment
1	DIN3+	Data In +ve
6	DIN3-	Data In -ve
2	SIN3+	Strobe In +ve
7	SIN3-	Strobe In -ve
3	SHIELD	Inner Shield
8	SOUT3+	Strobe Out +ve
4	SOUT3-	Strobe Out -ve
9	DOUT3+	Data Out +ve
5	DOUT3-	Data Out -ve

Table 4-10: J8 SPW-3 interface connections

FUNCTION	ASIC pin	CONNECTOR PIN	ASIC pin	FUNCTION
DGND		1	120	DGND
+5V		2	119	+5V
DGND		3	118	DGND
-12V		4	117	-12V
DGND		5	116	DGND
+12V		6	115	+12V
DGND		7	114	DGND
D15	64	8	113	D31
D7	52	9	112	D23
+3.3V		10	111	+3.3V
DGND		11	110	DGND
D14	63	12	109	D30
D6	51	13	108	D22
D13	62	14	107	D29
D5	50	15	106	D21
D12	60	16	105	D28
D4	48	17	104	D20
D11	59	18	103	D27
D3	47	19	102	D19
+3.3V		20	101	+3.3V
DGND		21	100	DGND
D10	58	22	99	D26
D2	46	23	98	D18
D9	57	24	97	D25
D1	45	25	96	D17
D8	53	26	95	D24
D0	43	27	94	D16
A26	38	28	93	A27
A24	33	29	92	A25
+3.3V		30	91	+3.3V
DGND		31	90	DGND
A22	31	32	89	A23
A20	28	33	88	A21
A18	26	34	87	A19
A16	23	35	86	A17
A14	21	36	85	A15
A12	18	37	84	A13
A10	16	38	83	A11
A8	11	39	82	A9
+3.3V		40	81	+3.3V
DGND		41	80	DGND
A6	9	42	79	A7
A4	6	43	78	A5
A2	4	44	77	A3
A0	1	45	76	A1
WRITEN	98	46	75	READ
OEN	99	47	74	IOSN
ROMSN0	103	48	73	ROMSN1
RAMSN4	123	49	72	RAMOEN4
+3.3V		50	71	+3.3V
DGND		51	70	DGND
RAMSN3	120	52	69	RAMOEN3
RAMSN2	119	53	68	RAMOEN2
RAMSN1	118	54	67	RAMOEN1
RAMSN0	117	55	66	RAMOEN0
RWEN2	109	56	65	RWEN3
RWEN0	105	57	64	RWEN1
BRDYN	141	58	63	BEXCN
RESETN	136	59	62	CLK
DGND		60	61	DGND

Table 4-11: Expansion connector J9 Pin-out

FUNCTION	ASIC pin	CONNECTOR PIN		FUNCTION
GPIO0	191	1	2	DGND
GPIO1	192	3	4	DGND
GPIO2	193	5	6	DGND
GPIO3	194	7	8	DGND
GPIO4	196	9	10	DGND
GPIO5	197	11	12	DGND
GPIO6	198	13	14	DGND
GPIO7	199	15	16	DGND
GPIO8	254	17	18	DGND
GPIO9	255	19	20	DGND
GPIO10	256	21	22	DGND
GPIO11	257	23	24	DGND
GPIO12	259	25	26	DGND
GPIO13	260	27	28	DGND
GPIO14	261	29	30	DGND
GPIO15	262	31	32	DGND
+3.3V		33	34	DGND

Table 4-12: J10 PIO Header Pin out

FUNCTION	ASIC pin	CONNECTOR PIN		FUNCTION	
DGND		1	60	DGND	
CB6	96	2	59	97	CB7
CB4	93	3	58	94	CB5
CB2	91	4	57	92	CB3
CB0	89	5	56	90	CB1
		6	55		
		7	54		
		8	53		
		9	52		
DGND		10	51	DGND	
+3.3V		11	50	+3.3V	
		12	49		
		13	48		
		14	47		
		15	46		
		16	45		
		17	44		
		18	43		
		19	42		
DGND		20	41	DGND	
+3.3V		21	40	+3.3V	
		22	39		
		23	38		
PCIO6		24	37	PCIO7	
PCIO4		25	36	PCIO5	
PCIO2		26	35	PCIO3	
PCIO0		27	34	PCIO1	
		28	33		
		29	32		
DGND		30	31	DGND	

Table 4-13: Expansion connector J11 Pin-out

Pin	Name	Comment
1	VDD	+5V Power
2	DM	Data Negative
3	DP	Data Positive
4	ID	Identifier
5	GND	Ground

Table 4-14: J12 DSU-Serial over USB MiniAB

Pin	Name	Comment
+VE	+5V	Inner Pin, 5V, typically TBD A
-VE	GND	Outer Pin Return

Table 4-15: J13 POWER – External Power Connector

Pin	Name	Comment
1	+5V	+5V, typically TBD A
2	GND	Ground
3	+12V	+12V Not used
4	GND	Ground

Table 4-16: J14 POWER – External Power Connector

FUNCTION	ASIC PIN	CONNECTOR PIN	ASIC PIN	FUNCTION
DGND		1	2	DGND
D31		3	4	CB7
D30		5	6	CB6
D29		7	8	CB5
D28		9	10	CB4
+3.3V		11	12	+3.3V
D27		13	14	CB3
D26		15	16	CB2
D25		17	18	CB1
D24		19	20	CB0
DGND		21	22	DGND
SDDQM3		23	24	SDDQM0
SDDQM2		25	26	SDDQM5 / pulled high
+3.3V		27	28	+3.3V
A2		29	30	A5
A3		31	32	A6
A4		33	34	A7
DGND		35	36	DGND
D23		37	38	nc
D22		39	40	nc
D21		41	42	nc
D20		43	44	nc
+3.3V		45	46	+3.3V
D19		47	48	nc
D18		49	50	nc
D17		51	52	nc
D16		53	54	nc
DGND		55	56	DGND
nc		57	58	nc
nc		59	60	nc
SDCLK0		61	62	SDCKE0/ pulled high
+3.3V		63	64	+3.3V
SDRASN		65	66	SDCASN
SDWEN		67	68	SDCKE1/ pulled high
SDCSN0		69	70	A17
SDCSN1		71	72	A14
nc		73	74	SDCLK1
DGND		75	76	DGND
nc		77	78	nc
nc		79	80	nc
+3.3V		81	82	+3.3V
D15		83	84	nc
D14		85	86	nc
D13		87	88	nc
D12		89	90	nc
DGND		91	92	DGND
D11		93	94	nc
D10		95	96	nc
D9		97	98	nc
D8		99	100	nc
+3.3V		101	102	+3.3V
A8		103	104	A9
A10		105	106	A15 (SBA0)
DGND		107	108	DGND
A11		109	110	A16 (SBA1)
A12		111	112	A13
+3.3V		113	114	+3.3V
SDDQM1		115	116	SDDQM6 / pulled high
SDDQM0		117	118	SDDQM7 / pulled high
DGND		119	120	DGND
D7		121	122	nc
D6		123	124	nc
D5		125	126	nc
D4		127	128	nc
+3.3V		129	130	+3.3V
D3		131	132	nc
D2		133	134	nc
D1		135	136	nc
D0		137	138	nc
DGND		139	140	DGND
SDSDA / pulled high		141	142	SDSCL / pulled high
+3.3V		143	144	+3.3V

Table 4-17: SODIMM socket J15 Pin-out

4.2 List of Oscillators, Switches and LED's

Name	Function	Description
X1	OSC_MAIN	Main oscillator for ASIC DIL8 socket, 3.3V (75MHz as standard)
X2	OSC_ETH	Oscillator for Ethernet PHY transceiver, SMD type, 3.3V, 25.000MHz
X3	OSC_SPW	DIL8 socket for user installed SPW Clock Oscillator, 3.3V

Table 4-18: List and definition of Oscillators

Name	Function	Description
D1	POWER (3.3V)	Power indicator
D2	ERRORN	Leon processor in 'ERROR' mode
D3	DSUACT	Leon Debug Support Unit 'Active'
D4	WDOG	Watchdog indicator
D5	PROM_BUSY	Prom Write/Erase in Progress
D12	DSU_ACTIVITY	Bi-color LED indicating RX and TX activity on Serial DSU (USB) interface

Table 4-19: List and definition of PCB mounted LED's

Name	Function	Description
S1	RESET	Push button RESET switch
S2	DSU_BREAK	Push button DSU_BREAK switch
S3	PIO[7..0]	8 pole dip switch for PIO configuration – see Table 4-21
S4	PIO[15..8]	8 pole dip switch for PIO configuration – see Table 4-22

Table 4-20: List and definition of Switches





FUNCTION	ASIC pin	OPEN	SWITCH	CLOSED
PIO0	191	'1'		'0'
PIO1	192	'1'		'0'
PIO2	193	'1'		'0'
PIO3	194	'1'		'0'
PIO4	196	'1'		'0'
PIO5	197	'1'		'0'
PIO6	198	'1'		'0'
PIO7	199	'1'		'0'

Table 4-21: DIP Switch S3 'PIO[7..0]'

FUNCTION	ASIC pin	OPEN	SWITCH	CLOSED
PIO8	254	'1'	1	'0'
PIO9	255	'1'	2	'0'
PIO10	256	'1'	3	'0'
PIO11	257	'1'	4	'0'
PIO12	259	'1'	5	'0'
PIO13	260	'1'	6	'0'
PIO14	261	'1'	7	'0'
PIO15	262	'1'	8	'0'

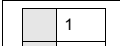
Table 4-22: DIP Switch S4 'PIO[15..8]' definition

4.3 List of Jumpers

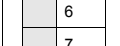
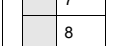
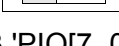
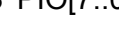
Name	Function	Type	Description
JP1	CONFIG	4x2 pin 0.1" Header	Header for DSU, PROM and WDOG enable
JP2	ETH_INTR	2 pin 0.1" Header	Enable Disable for Ethernet Interrupt
JP3	CAN_TERM0	2x2 pin 0.1" Header	Header for configuration of Termination of CAN0 i/f
JP4	CAN_TERM1	2x2 pin 0.1" Header	Header for configuration of Termination of CAN1 i/f
JP5	RAM_BANK	4x2 pin 0.1" Header	Header for configuration of RAM bank select
JP6	ROM_SELECT	4x2 pin 0.1" Header	Header for configuration of EEPROM/FLASH
JP7	PCI_CLK	2x2 pin 0.1" Header	Configures PCI Clocks for Host/Peripheral Mode
JP8	PCI_PULLUPS	10x2 pin 0.1" Header	Configures Host mode PCI signal pull ups
JP9	PCI_REQN	4 pin 0.1" Header	Configures PCI_REQN for Host/Peripheral Mode
JP10	PCI_GNTN	4 pin 0.1" Header	Configures PCI_GNTN for Host/Peripheral Mode
JP11	FP_LEDS	4x2 pin 0.1" Header	Header to connect or front panel LED's
JP12	VIN_SELECT	3pin 0.1" Header	Install jumper in position 1-2 for use with +5V main power input is to be used to generate +3.3V on board and +2.5V (Vcore). Connect 2-3 if 3.3V PCI power is to be used to provide +3.3V on board and to generate +2.5V (Vcore).
JP13	3.3V_SELECT	3 pin 0.1" Header	Install same as JP12
JP14	I1V8	2 pin 0.1" Header	Measure point for 1.8V current (Link normally installed)
JP15	I3V3	2 pin 0.1" Header	Measure point for 3.3V current (Link normally installed)
JP16	RESET_BREAK	2x2 pin 0.1" Header	Pins for Front Panel RESET and BREAK switches
JP17	SPW_CLK	2 pin 0.1" Header	Header to connect ASIC clock as SPW_CLK
JP18	PCI_RSTN	2 pin 0.1" Header	Connects board RESETN to PCI_RSTN for Host mode

Table 4-23: List and definition of PCB Jumpers

(for details refer to schematic)

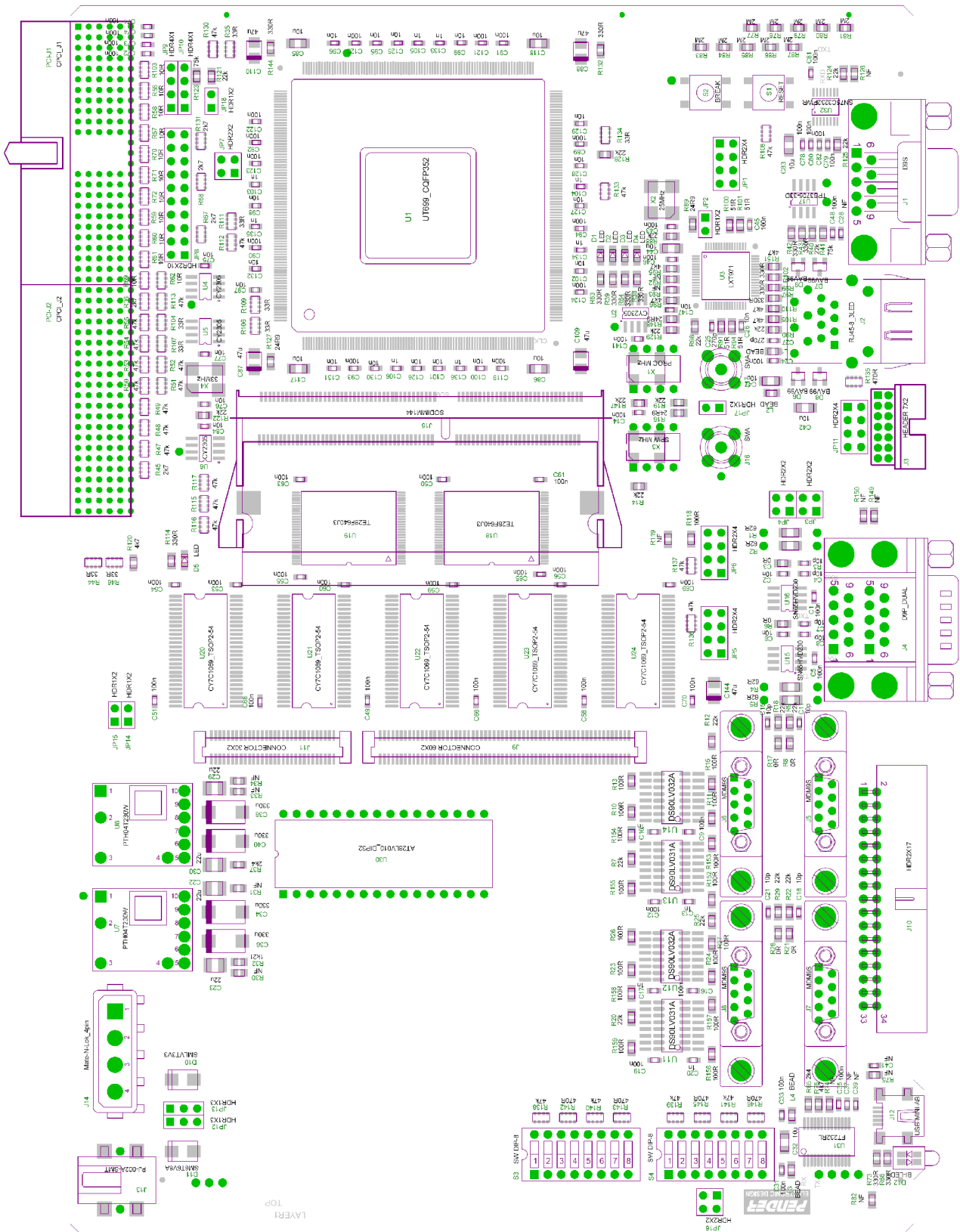

Figure 4-2: PCB Top View

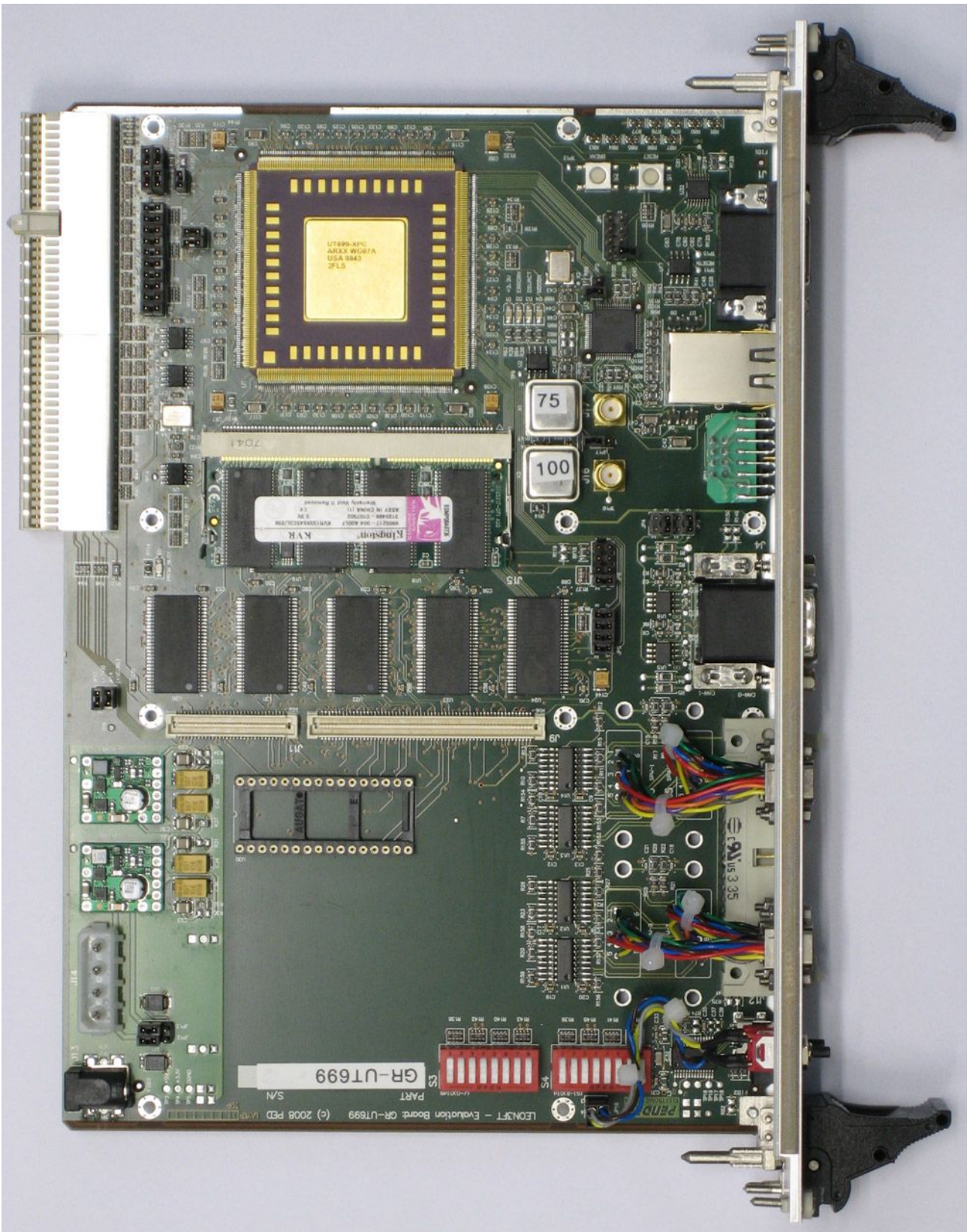

Figure 4-3: GR-UT699 Assembly Photo