

GR716-BOARD User's Manual

May 2024, Version 1.1

TABLE OF CONTENTS

1	Introduction.....	4
1.1	Scope and Purpose of the Document.....	4
1.2	Reference Documents.....	4
2	Abbreviations.....	4
3	Introduction.....	5
3.1	Overview.....	5
3.2	Handling.....	6
4	Board Design.....	7
4.1	Board Block Diagram.....	7
4.2	Board Mechanical Configuration.....	8
4.3	GR716 Microcontroller.....	11
4.4	Memory.....	12
4.5	LVDS Interfaces.....	13
4.6	GPIO.....	14
4.7	Bootstrap Signals.....	14
4.8	Debug Support Unit Interfaces.....	15
4.9	Oscillators and Clock Inputs.....	16
4.10	Power Supply and Voltage Regulation.....	17
4.11	Reset Circuit and Button.....	20
4.12	Watchdog.....	20
5	Setting Up and Using the Board.....	20
6	Interfaces and Configuration.....	21
6.1	List of connectors.....	21
6.2	List of Oscillators, Switches and LED's.....	23

List of Figures

Figure 3-1	GR716-BOARD Development Board	5
Figure 4-1	GR716-BOARD Board Block Diagram	7
Figure 4-2	GR616-BOARD Board Dimensions.....	8
Figure 4-3	GR716-BOARD mounted on a GR716-CPCI-DEV Carrier board	9
Figure 4-4	GR716-TEST-MEMORY BOARD.....	10
Figure 4-5	GR716-TEST-ADCDAC BOARD.....	10
Figure 4-6	GR716 Microcontroller Block Diagram	11
Figure 4-7	GR716 Package.....	11
Figure 4-8	SPI Boot Memory Connectons	12
Figure 4-9	Debug Support Unit connections.....	15
Figure 4-10	GR716-DSU-USB Adapter	15
Figure 4-11	Board level Clock Distribution Scheme	16
Figure 4-12	Power Regulation Scheme	18
Figure 4-13	Power Supply Configuration Jumpers.....	19
Figure 6-1	PCB Top View	24
Figure 6-2	PCB Bottom View.....	25
Figure 6-3	PCB Top View (Photo).....	26
Figure 6-4	PCB Bottom View (Photo).....	27

List of Tables

Table 1: Bootstrap Resistor Settings	14
Table 2: List of Connectors	21
Table 3: J1 Screw Terminal Connector for Input Voltages	21
Table 4: J2 POWER-External Power Connector	21
Table 5: Expansion connector P1 Pin-out	22
Table 6: Expansion connector P2 pin-out	22
Table 7: List and definition of Oscillators and Crystals	23
Table 8: List and definition of PCB mounted LED's	23
Table 9: List and definition of Switches	23
Table 10: Definition of Switch S1 functions (refer to [RD1])	23

1 INTRODUCTION

1.1 Scope and Purpose of the Document

This document provides a User's Manual and Interface document for the "GR716-BOARD" Development and Demonstration board.

The work has been performed by Frontgrade Gaisler AB, Göteborg, Sweden.

1.2 Reference Documents

- [RD1] GR716, Data Sheet and User's Manual", Frontgrade Gaisler, GR716-UM-DS, available from <http://www.gaisler.com/index.php/products/components/GR716>
- [RD2] GR716-BOARD_schematic.pdf, Schematic
- [RD3] GR716-BOARD_assy_drawing.pdf, Assembly Drawing
- [RD4] GRMON3 User's Manual, available from: <https://www.gaisler.com/index.php/products/debug-tools/grmon3>

2 ABBREVIATIONS

ASIC	Application Specific Integrated Circuit.
DSU	Debug Support Unit
EDAC	Error Detection and Correction
ESA	European Space Agency
ESD	Electro-Static Discharge
ESTEC	European Space Research and Technology Center
GPIO	General Purpose Input / Output
IC	Integrated Circuit
I/O	Input/Output
IP	Intellectual Property
LDO	Low Drop-Out
PCB	Printed Circuit Board
POL	Point of Load
SOC	System On a Chip
SPW	Spacewire
TBC	To Be Confirmed
TBD	To Be Defined

3 INTRODUCTION

3.1 Overview

This document describes the GR716-BOARD Development Board.

This equipment is intended to be used as a platform for the demonstration of the Frontgrade Gaisler GR716 RAD Hard Microcontroller.

Furthermore, this board provides developers with a convenient hardware platform for the evaluation and development of software for the GR716 microcontroller.

The GR716 Microcontroller features a fault-tolerant LEON3 SPARC V8 processor, communication interfaces and on-chip ADC, DAC, Power-on-Reset, Oscillator, Brown-out detection, LVDS transceivers, regulators to support for single 3.3V supply, ideally suited for space and other high-rel applications.

The GR716 Microcontroller is a complex device with multifunctional pins whose function depend on the mode of operation and programming of internal registers of the device. This board treats the pins in a generic manner to allow easy access to all the pins and features of the GR716 microcontroller.

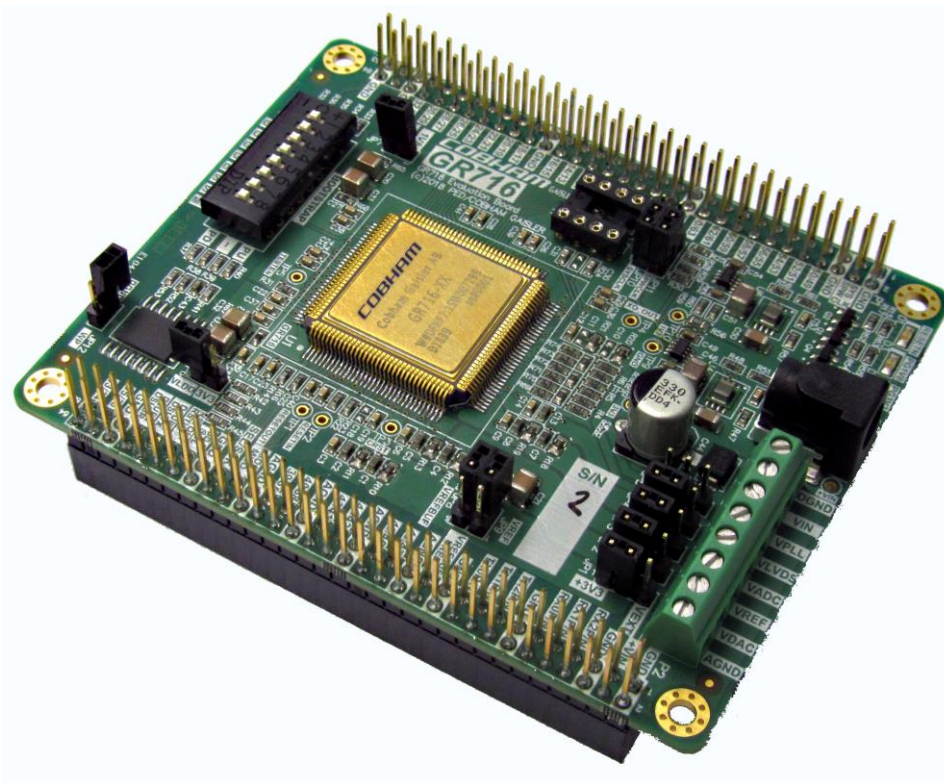

Figure 3-1 GR716-BOARD Development Board

The board contains the following main items as detailed in section 0 of this document:

- size 80 x 100mm
- two 2x32 pin stackable 0.1" headers allowing access to all I/O pins
- connector for single VIN power input (+5V to +12V)
- alternative connector for connections to individual device power supplies
- jumpers for power supply configuration
- on-board regulators converting from VIN to 3.3V & 1.8V
- 256 Mbit SPI memory (Cypress, S25FL256SAGN in 8 pin WSON package)
- socket for crystal (25MHz TBC)
- DIP switch for bootstrap settings
- on-board I2C voltage/current measurement

3.2 Handling



ATTENTION: OBSERVE PRECAUTIONS FOR HANDLING ELECTROSTATIC SENSITIVE DEVICES

This unit contains sensitive electronic components which can be damaged by Electrostatic Discharges (ESD). When handling or installing the unit observe appropriate precautions and ESD safe practices.

When not in use, store the unit in an electrostatic protective container or bag.

When configuring the jumpers on the board, or connecting/disconnecting cables, ensure that the unit is in an un-powered state.

When operating the board in a 'stand-alone' configuration, the power supply should be current limited to prevent damage to the board or power supply in the event of an over-current situation.

This board is intended for commercial use and evaluation in a standard laboratory environment, nominally, 20°C. All devices are standard commercial types, intended for use over the standard commercial operating temperature range (0 to 70°C).

4 BOARD DESIGN

4.1 Board Block Diagram

The GR716-BOARD Board provides the electrical functions and interfaces as represented in the block diagram, Figure 4-2.

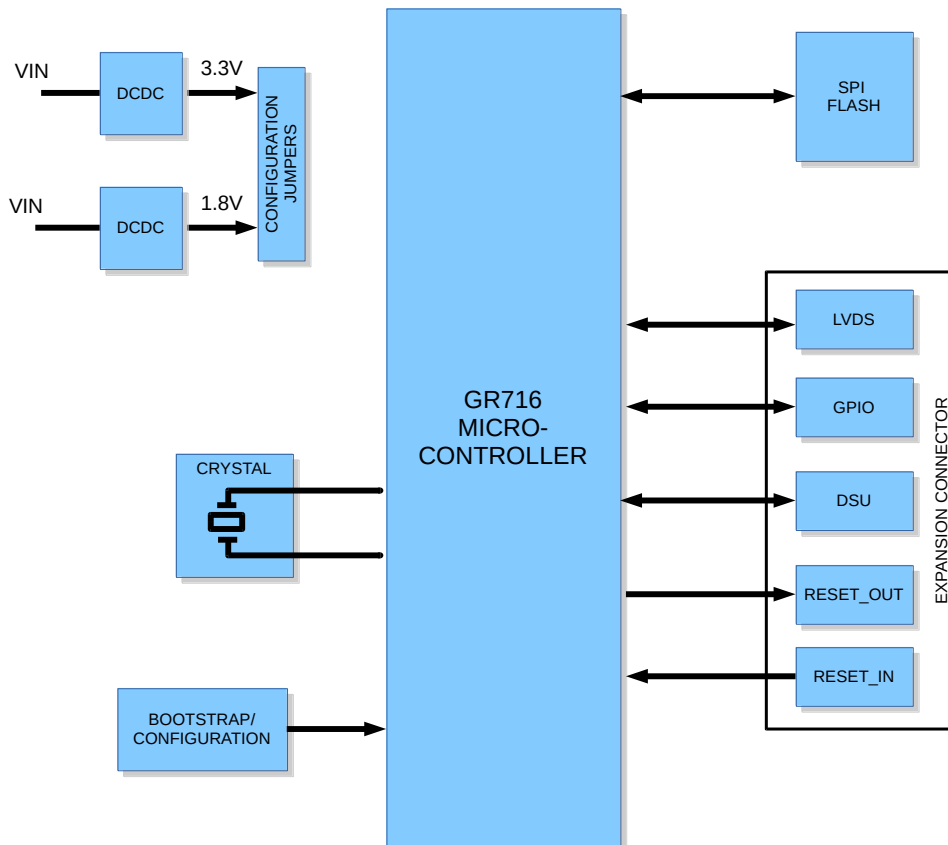

Figure 4-1 GR716-BOARD Board Block Diagram

Note that not all features and interfaces are available at the same time, and the configuration of on-board resistors plus programming of registers is required to access some of the features.

4.2 Board Mechanical Configuration

The board (80 x 100mm) and can be used 'stand-alone' on the bench-top simply an external +5V power supply connected to connector J2. For mounting of the board on a carrier or expansion board, four M2.5 mounting holes are provided in the corners of the board, as shown in the figure below.

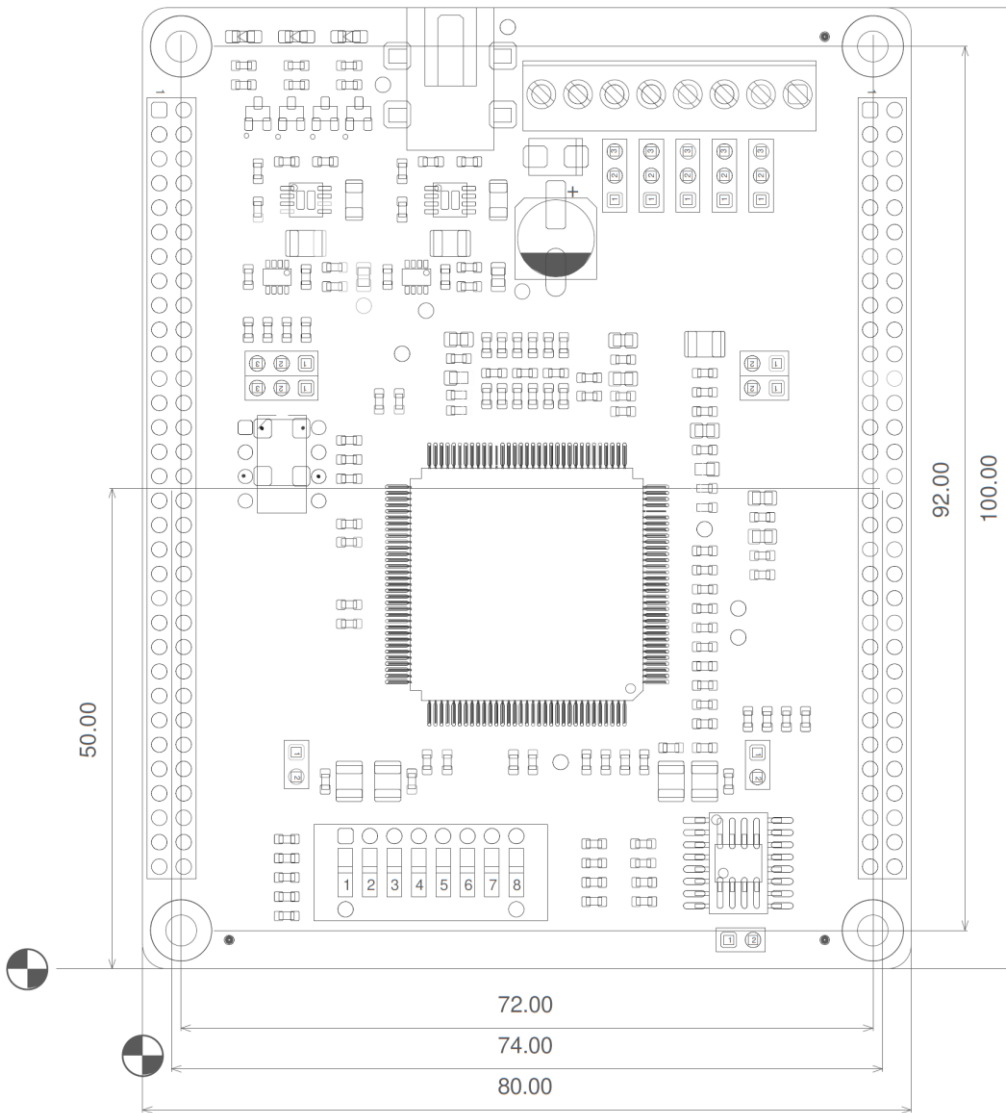

Figure 4-2 GR716-BOARD Board Dimensions

The expansion connectors P1 and P2 of the GR716-BOARD are stacking style connectors having a socket on the bottom side and an extended pin on the top side. In a stand-alone configuration the pins on the top side allow easy access for Logic Analyser or Oscilloscope probing for all the functional microcontroller pins.

The sockets on the bottom side allow the board to be plugged on to a carrier board to conveniently enable further development testing.

The CPCI format board providing GPIO, SPW, Serial (via FTDI-USB) and analog coaxial connector which has been developed for this purpose is shown in Figure 4-3.

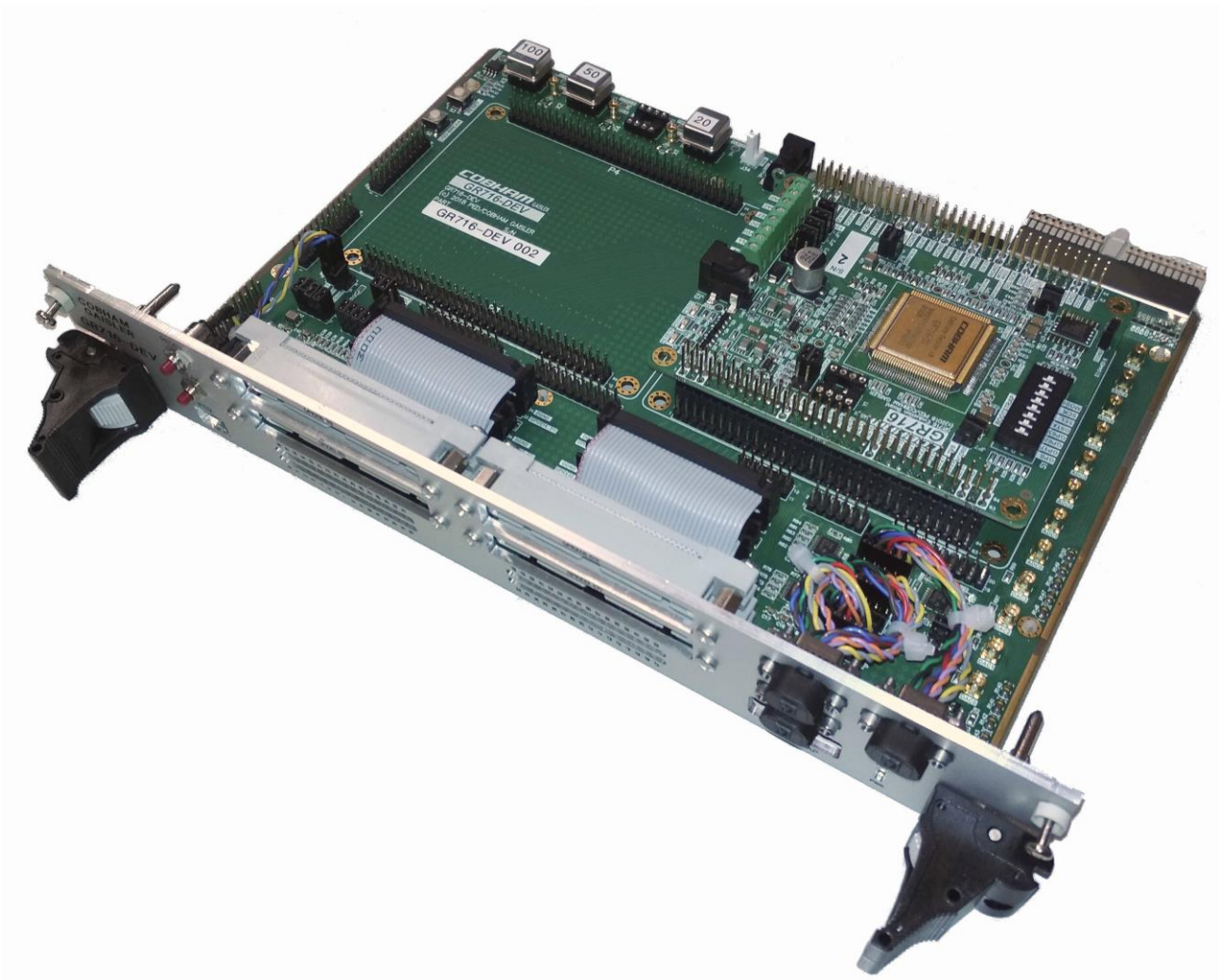

Figure 4-3 GR716-BOARD mounted on a GR716-CPCI-DEV Carrier board

Alternatively, the stacking connector concept allows the interface functions to be expanded by stacking the GR716-BOARD to other boards in a concept similar to PC104.

A test board for adding memory (SPI serial, 8 bit parallel FLASH and 8 bit SRAM) is shown in Figure 4-4, and a test board for exercising the Analog features of the GR716 microcontroller is shown in Figure 4-5.

This concept also provides a convenient way for User Defined interface boards to be developed and connected to the GR716-BOARD, if other functions or features are to be demonstrated.

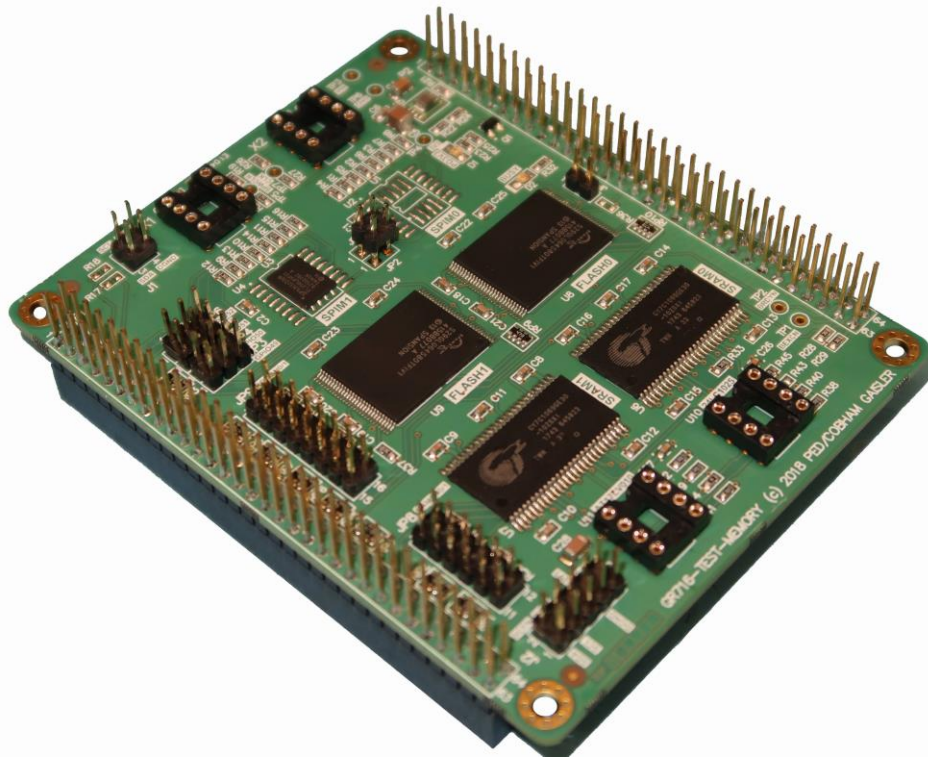

Figure 4-4 GR716-TEST-MEMORY BOARD

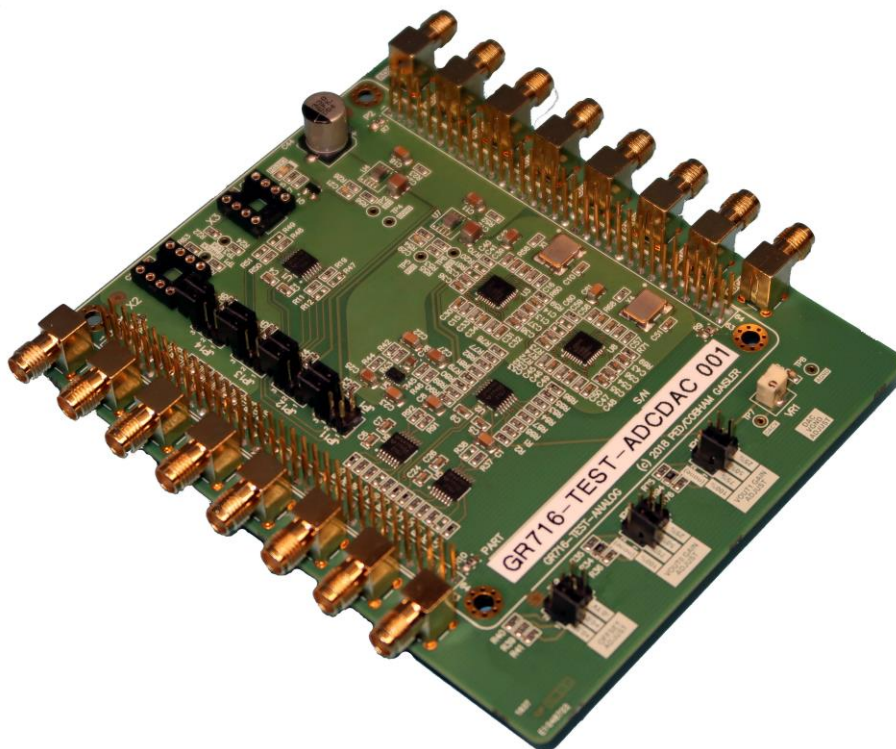

Figure 4-5 GR716-TEST-ADCDAC BOARD

4.3 GR716 Microcontroller

The *Frontgrade Gaisler GR716 Microcontroller* features a fault-tolerant LEON3 SPARC V8 processor, communication interfaces and on-chip ADC, DAC, Power-on-Reset, Oscillator, Brown-out detection, LVDS transceivers, regulators to support for single 3.3V supply, ideally suited for space and other high-rel applications.

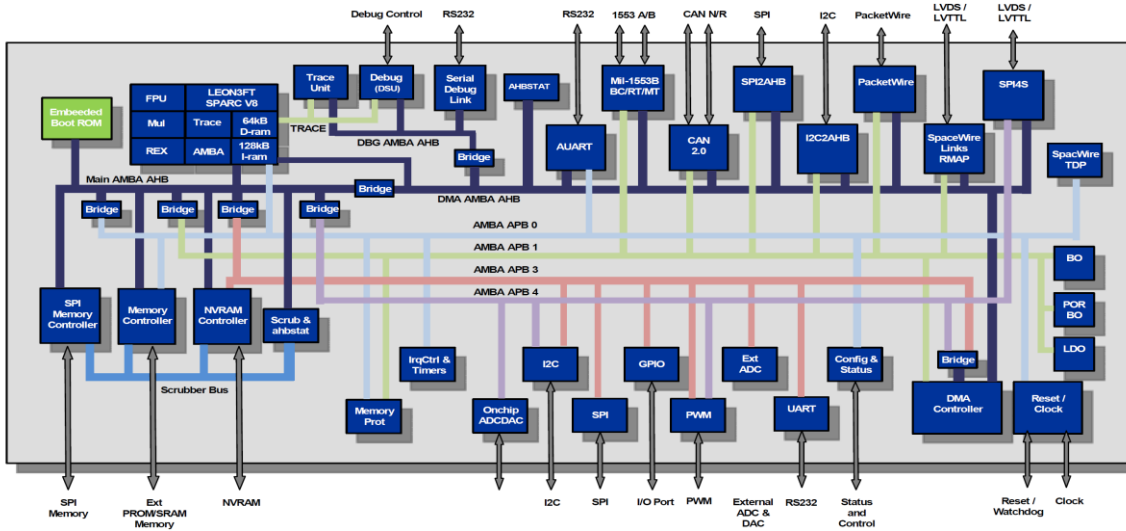

Figure 4-6 GR716 Microcontroller Block Diagram

The GR716 Microcontroller is a complex device with many modes of operation. For the details of the interfaces, operation and programming, refer to [RD1].

The GR716 microcontroller is packaged in a 132-pin, 0.635mm pitch Ceramic Quad Flat Pack package (housing: 24 x 24 mm).



Figure 4-7 GR716 Package

4.4 Memory

The memory configuration installed on the board comprises:

- 256 Mbit SPI serial boot prom (Cypress, S25FL256SAGN)

The SPI boot memory is connected directly to the SPIM interface of the GR716 Micro-controller. Although the SPI memory chip can operate in a x4 data mode, only a x1 data mode is usable with the GR716.

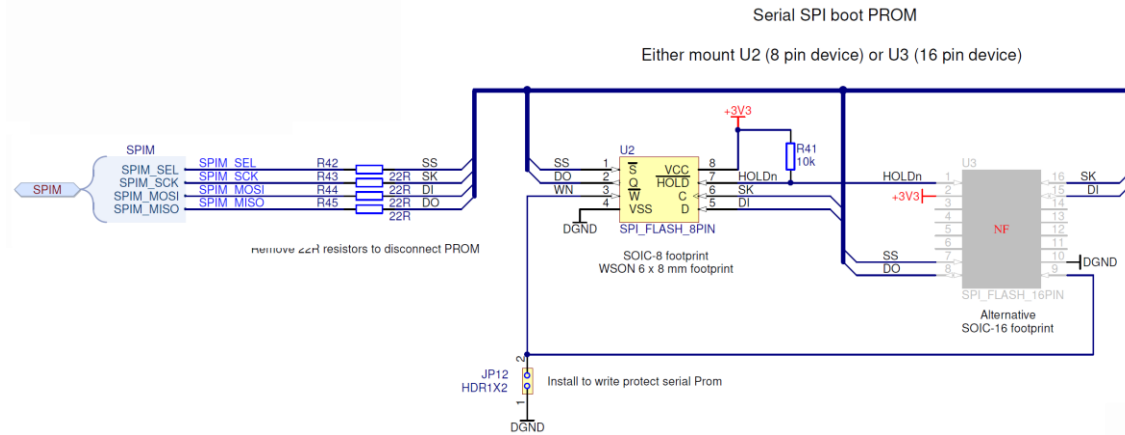

Figure 4-8 SPI Boot Memory Connectons

4.5 LVDS Interfaces

The GR716 microcontroller provides a set of three LVDS input pairs and three LVDS output pairs which are configurable from software via configuration registers to provide SpaceWire or SPI4SPACE interfaces.

These signals are connected from the GR716 microcontroller to the Expansion connector, P2.

100 Ohm Termination resistors and fail-safe resistors for the LVDS receiver signals are mounted on the board close to the receiver.



This equipment has SPW ports that use Low Voltage Differential Signalling (LVDS) which has limited common mode voltage protection. To avoid damage to the SPW interfaces due to common mode voltage the following actions should be performed before the equipments that will be connected by SpaceWire are powered on.

- Before connecting any SpaceWire cables, make sure that there is no voltage difference between the different equipment grounds. E.g., measure the voltage between the different equipment grounds with a voltmeter. The result should be close to 0 V.
- After the SpaceWire cables are connected, make sure that the equipment grounds are low ohmic connected to each other. E.g., measure the resistance between the different equipment grounds with a multimeter in resistance mode. The result should be less than 1 Ω .

This board is intended to be used together with a carrier board. See the user's manual of the carrier board for information about the connection and grounding of the SpaceWire interface. Users using the board stand alone or design their own carrier board, must ensure that equipments connected via SPW have grounds that are connected together.

4.6 GPIO

All 64 GPIO pins are connected from the GR716 Microcontroller to the Expansion connector.

These General purpose I/O pins are 3.3V LVCMOS voltage levels.

Note though that most pins have multiple functions and in certain configurations may have different input/output voltage requirements (e.g. ADC and DAC signals). Care must be taken to account for this.



No current limiting or overvoltage protection components are included on the GPIO signals of the GR716-BOARD board. The signals are connected directly from the microcontroller to the expansion connector. Care must therefore be taken to ensure that any external circuitry connected does not exceed the allowable voltage limits for the input/output pins.

4.7 Bootstrap Signals

A number of features of the GR716 microcontroller are required to be set at power-on of the processor, by means of bootstrap pins. A number of GPIO and function pins are pre-defined for this purpose, according the definition Table 22 of [RD1].

To define the desired setting, an 8 pole, Double-Throw DIP switch (S1), is provided on the board to connect these signals to either a pull-up or a pull-down resistor, or to allow the pin to float.

Table 1: Bootstrap Resistor Settings

Pin	Function			Default
GPIO0	Disable EDAC			Up
GPIO17	Bypass Internal Boot Prom			Down
GPIO62	Enable Memory Test			Down
GPIO63	Redundant Memory Available			Down
DSUTX	Copy ASW image/SPW default frequency			Down
SPIM_MOS	Remote Access/Boot from Memory			Down
SPIM_SCK	Boot Source 0			Down
SPIM-SEL	Boot Source 1			Down

4.8 Debug Support Unit Interfaces

Program download and debugging to the processor is performed using the GRMON Debug Monitor tool from Frontgrade Gaisler ([RD4]). The GR716 microcontroller provides a UART based DSU interface for Debug and control of the processor by means of a host terminal, as represented in Figure 4-9.

Four control signals from the Debug Support Unit interface to the processor are implemented:

DSUTX	Debug UART Transmit
DSURX	Debug UART Receive
DSUEN	This signal is pulled high on the board to enable Debugging
DSUBRE	This signal is pulled low on the board

To connect to a host computer, a small adapter can be used as shown in Figure 4-10.

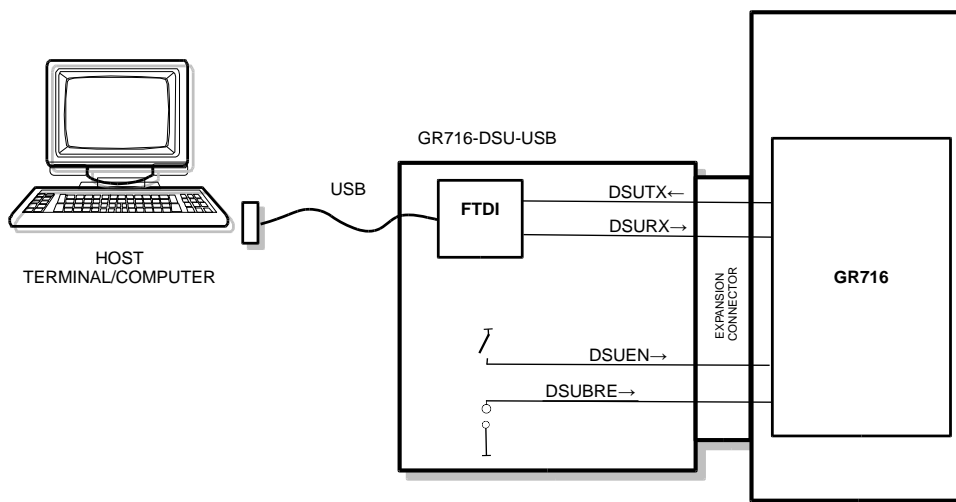

Figure 4-9 Debug Support Unit connections

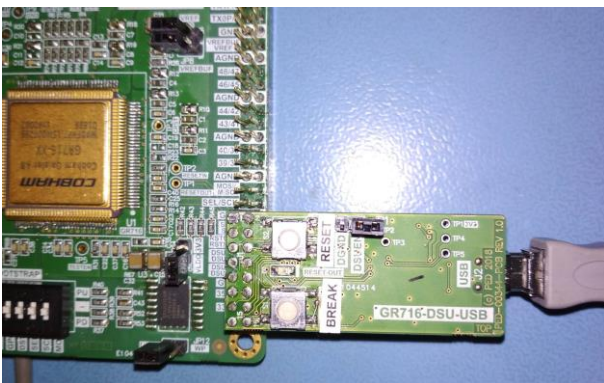

Figure 4-10 GR716-DSU-USB Adapter

4.9 Oscillators and Clock Inputs

The oscillator and clock scheme for the GR716-BOARD Board is shown in Figure 4-11.

Two oscillator inputs are required: CLK for the main system clock, and SPW_CLK for the SpaceWire clock of the microcontroller

To allow the GR716 Microcontroller to operate in a stand alone manner a crystal is required on the board which is connected to the Crystal oscillator interface for the GR716. On this board the crystal is mounted on a DIL8 socket adapter in order to allow various crystal frequencies to be tested.

This generates an output clock, XO_OUT, which is connected to the CLK and SPW_CLK inputs with jumpers.

In an alternative scenario, it may be preferred to have a separate CLK or SYS_CLK to allow different frequencies to be used. In this case the jumpers can be moved and instead an external 3.3V LVCMOS clock signal provided via the expansion connector.

For more details of the internal Crystal Oscillator, PLL structure and clock gating features of the GR716, please refer to sections 9 and 10 of [RD1].

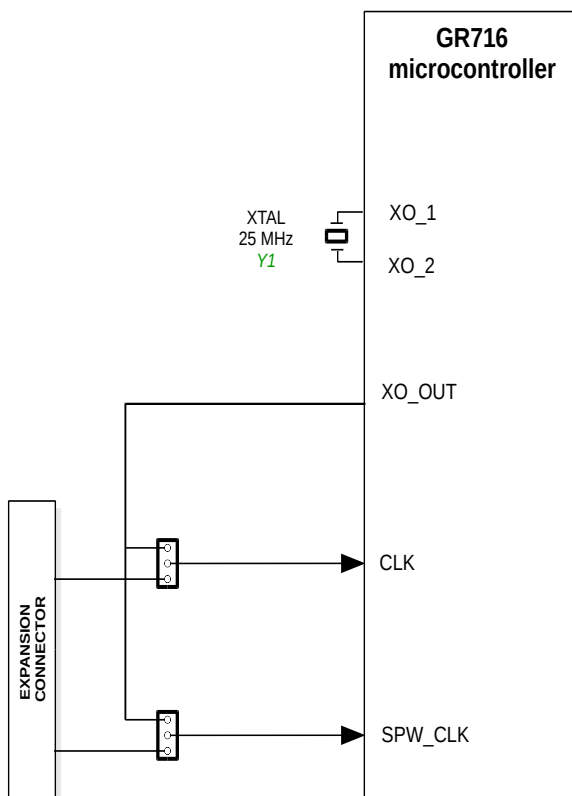

Figure 4-11 Board level Clock Distribution Scheme

4.10 Power Supply and Voltage Regulation

The power configuration is represented in Figure 4-12.

By means of configuration jumpers, several configurations can be tested:

1. Individual voltages from external bench supplies connected to the screw terminal connector J1 to provide

+VADC	(+3V3 nominal)
+VREF	(+3V3 nominal)
+VDAC	(+3V3 nominal)
+VLVDS	(+3V3 nominal)

This allows individual power supplies to be tested over min/nom/max by varying the supply voltages.

2. Single VIN (+12V nominal) input supply connector to J1.
3. Single VIN (+12V nominal) input supply connector to J2.
4. VIN provided from external circuitry connected to Expansion connector P2.

With reference to the setting of the jumpers shown in Figure 4-13:

- In case 1, jumpers JP1, JP2, JP3 and JP4 should be set to position 2-3.
- In cases 2,3,4 VIN is regulated with two LMZ21701 micro Point-of-Load regulators to generate a regulated VDDIO (+3.3V) and VDD_CORE (+1.8V). In these cases, jumpers JP1, JP2, JP3 and JP4 should be set to position 1-2.
- Jumper JP5 (VPLL) should not be installed. VPLL is provided from the 1V8 voltage generated by the LDO regulator inside the GR716.
- If the GR716 is to be operated from a single 3.3V, and the internal LDO is to be used to generate the VDDCORE voltage of 1.8V then JP6 should be installed and JP7 removed.
- If the GR716 is to be operated from both the POL generated 3.3V and 1.8V supplies, then JP6 should be removed and JP7 installed. In this situation, the internal LDO is disabled and VDDCORE voltage of 1.8V is provided from the POL regulator.

At the output of the 3.3V and 1.8V POL regulators, 20 mOhm sense resistors and INA219 Current/Power Monitor circuits with an I2C interface are incorporated on the board. The I2C signals (SDA, SCL) are connected to the Expansion connector P2 to allow the current/voltage to be measured using an I2C master circuit.

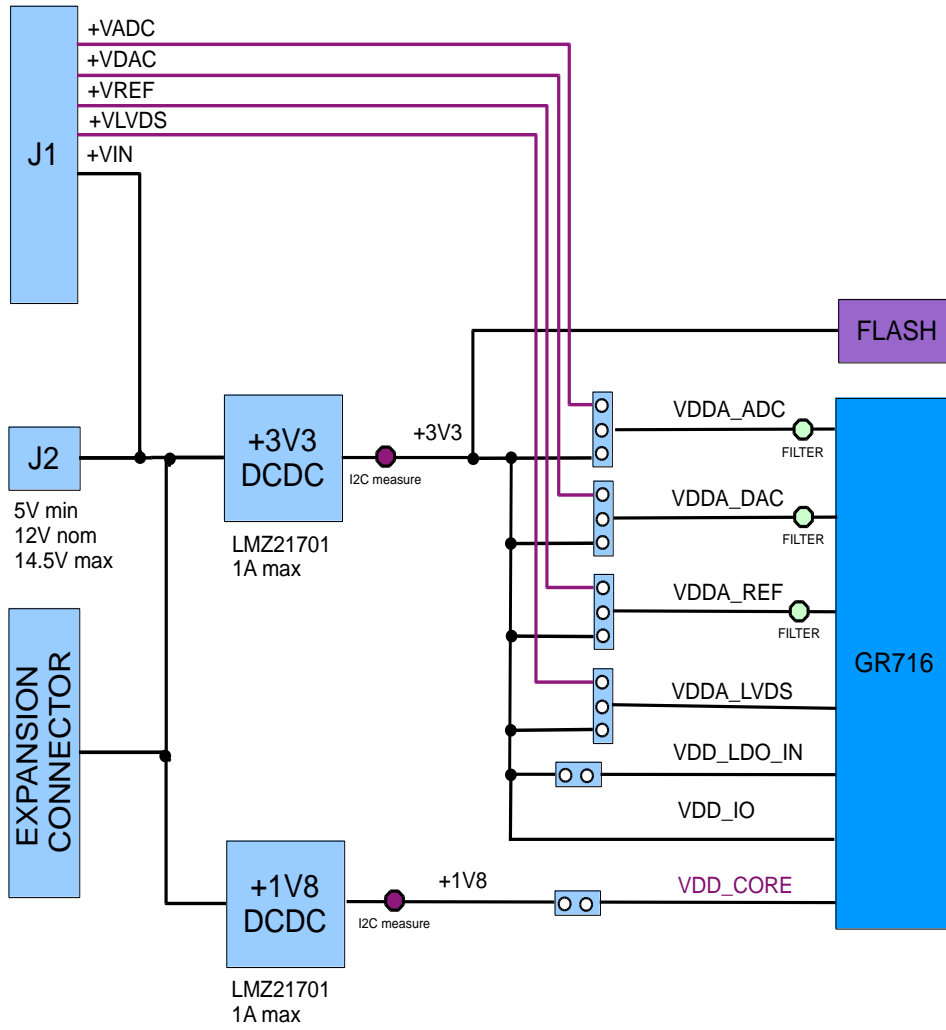

Figure 4-12 Power Regulation Scheme

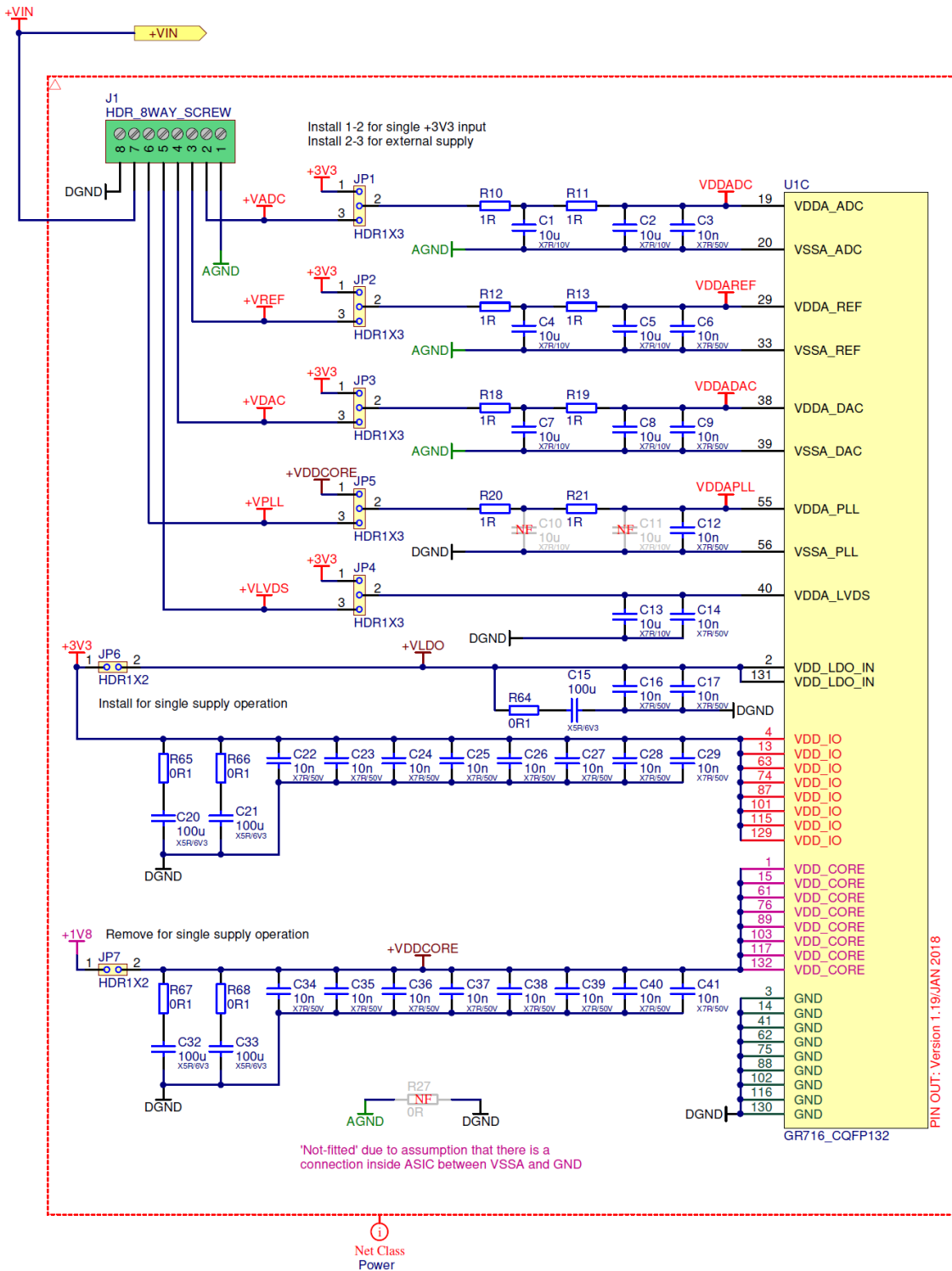

Figure 4-13 Power Supply Configuration Jumpers

4.11 Reset Circuit and Button

The GR716 microcontroller includes an internal RESET circuit with Brown-out detector to reset the processor and its peripherals (see section 8 of [RD1]).

The resulting low reset signal is present on the microcontroller pin RESET_OUT_N. This signal is connected to the expansion connector, P2.

A manual reset of the microcontroller can be generated using the RESET_IN_N signal. This signal is present on the expansion connector P2, and can be driven from an external circuitry if required. A miniature push button switch is provided on the GR716-DSU-USB (Figure 4-10) to pull this signal low, when the button is pressed.

4.12 Watchdog

The GR716 microcontroller includes an internal Watchdog timer function which can be used for the purpose of generating a system reset in the event of a software malfunction or crash. Please refer to [RD1].

5 SETTING UP AND USING THE BOARD

The board is provided with a default configuration set by bootstrap settings.

For additional information, refer to [RD2] and for information about the Bootstrap signals, refer to section 4.7.

To operate the board stand alone on the bench top, install the power configuration jumpers appropriately, and +12V supply to the board connector J2.



ATTENTION! To prevent damage to board, please ensure that the correct power supply voltage and polarity is used with the board.

Do not exceed +14.5V at the power supply input, as this may damage the board.

The POWER_3V3 and POWER_1V8 power good LED's should be illuminated indicating that the power supply is present and the board is generating the supply voltages that it requires.

Upon power on, using default bootstrap the processor will start executing instructions beginning at the memory location 0x02000000, which is the start of the PROM. If the PROM is 'empty' or no valid program is installed, the first executed instruction will be invalid, and the processor will halt with an ERROR condition.

To perform program download and software debugging on the hardware it is necessary to use the Frontgrade Gaisler GRMON3 debugging software, installed on a host PC (as represented in Figure 4-9). Please refer to the GRMON3 documentation for the installation of the software on the host PC (Linux or Windows), and for the installation of the associated hardware dongle.

To perform software download and debugging on the processor, a link from the Host computer to the DSU interface of the board is necessary. As described in section 0 this is achieved via the FTDI USB interface.

Program download and debugging can be performed in the usual manner with GRMON3. More information on the usage, commands and debugging features of GRMON3, is given in the GRMON3 Users Manuals and associated documentation, [RD4].

6 INTERFACES AND CONFIGURATION

6.1 List of connectors

Table 2: List of Connectors

Name	Function	Type	Description
J1	POWER	HDR_8_SCREW	Screw terminals for individual external power
J2	POWER_5V	2.1mm centre +ve	DC power input connector
PI	EXPANSION-1	2x32 pin 0.1" Header	Expansion connector-1
P2	EXPANSION-2	2x32 pin 0.1" Header	Expansion connector-2

Table 3: J1 Screw Terminal Connector for Input Voltages

Pin	Name	Comment
1	AGND	Analog Ground
2	+VADC	+3V3
3	+VREF	+3V3
4	+VDAC	+3V3
5	+VLVDS	+3V3
6	+VPLL	Do not apply voltage here
7	+VIN	+5V to +12V
8	DGND	Digital Ground

Table 4: J2 POWER-External Power Connector

Pin	Name	Comment
+VE	+VIN	Inner Pin, +5V to +12V, typically 1 A
-VE	DGND	Outer Pin Return

Table 5: Expansion connector P1 Pin-out

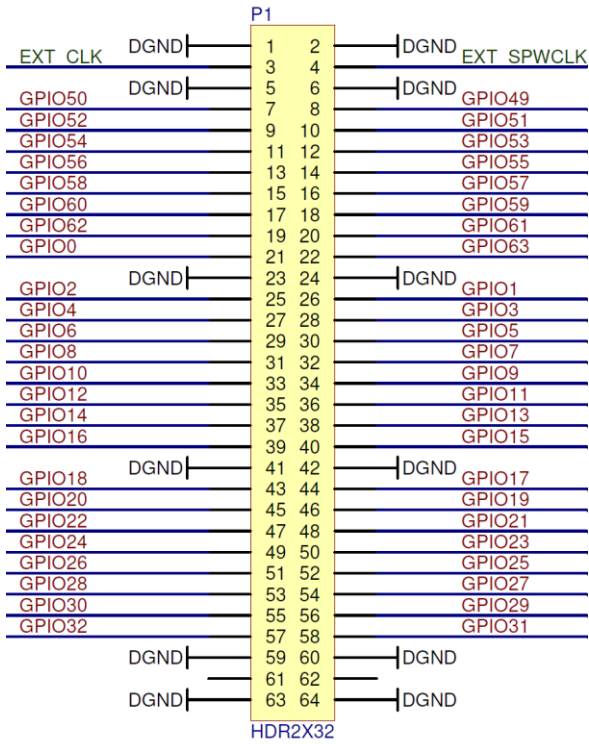
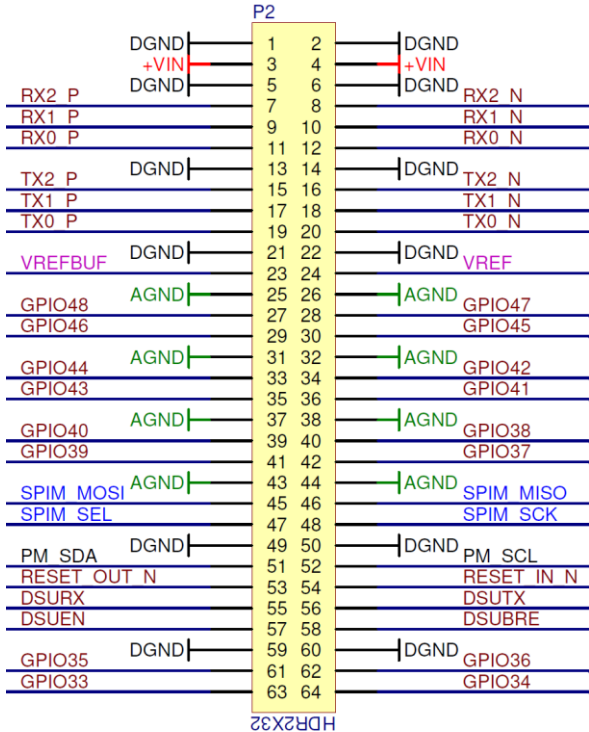

Table 6: Expansion connector P2 pin-out



6.2 List of Oscillators, Switches and LED's

Table 7: List and definition of Oscillators and Crystals

Name	Function	Description
Y1	XTAL	8 pin DIL socket for 5-25 MHz crystal

Table 8: List and definition of PCB mounted LED's

Name	Function	Description
D1	RESET_OUT	Processor RESET_OUT signal
D2	POWER_3V3	3.3V power good
D3	POWER_1V8	1.8V power good

Table 9: List and definition of Switches

Name	Function	Description
S1	8 pole SPDT DIP switch	Pull-up/Float/Pull-Down Bootstrap settings – see Error! Reference source not found.

Table 10: Definition of Switch S1 functions (refer to [RD1])

Name	Function	Description
S1-1	GPIO0	Disable EDAC
S1-2	GPIO17	Bypass Internal Boot Prom
S1-3	GPIO62	Enable Memory Test
S1-4	GPIO63	Redundant Memory Available
S1-5	DSUTX	Copy ASW image
S1-6	SPIM_SEL	Boot Source 0
S1-7	SPIM-SCK	Boot Source 1
S1-8	SPIM-MOSI	Remote access/Boot from memory

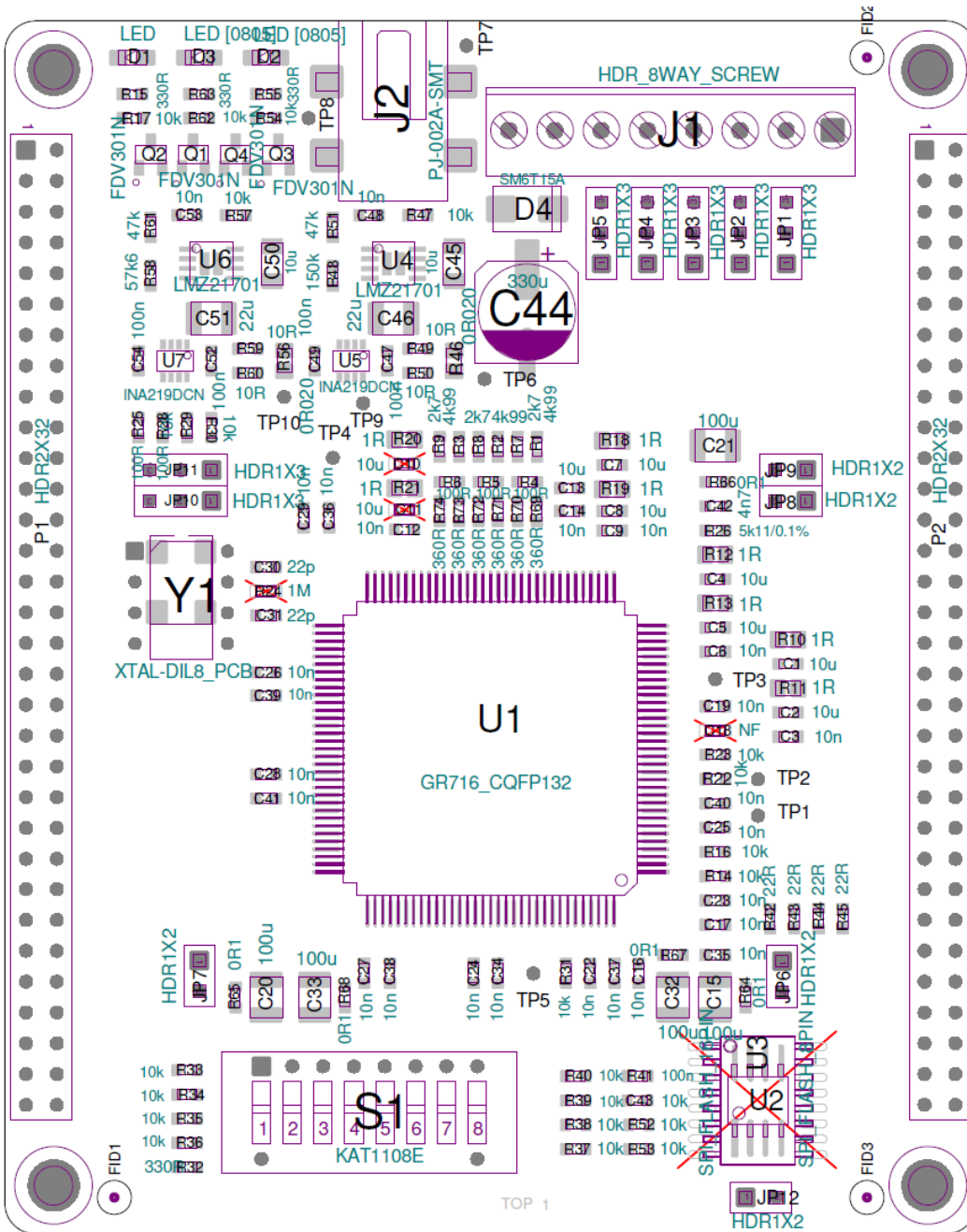

Figure 6-1 PCB Top View

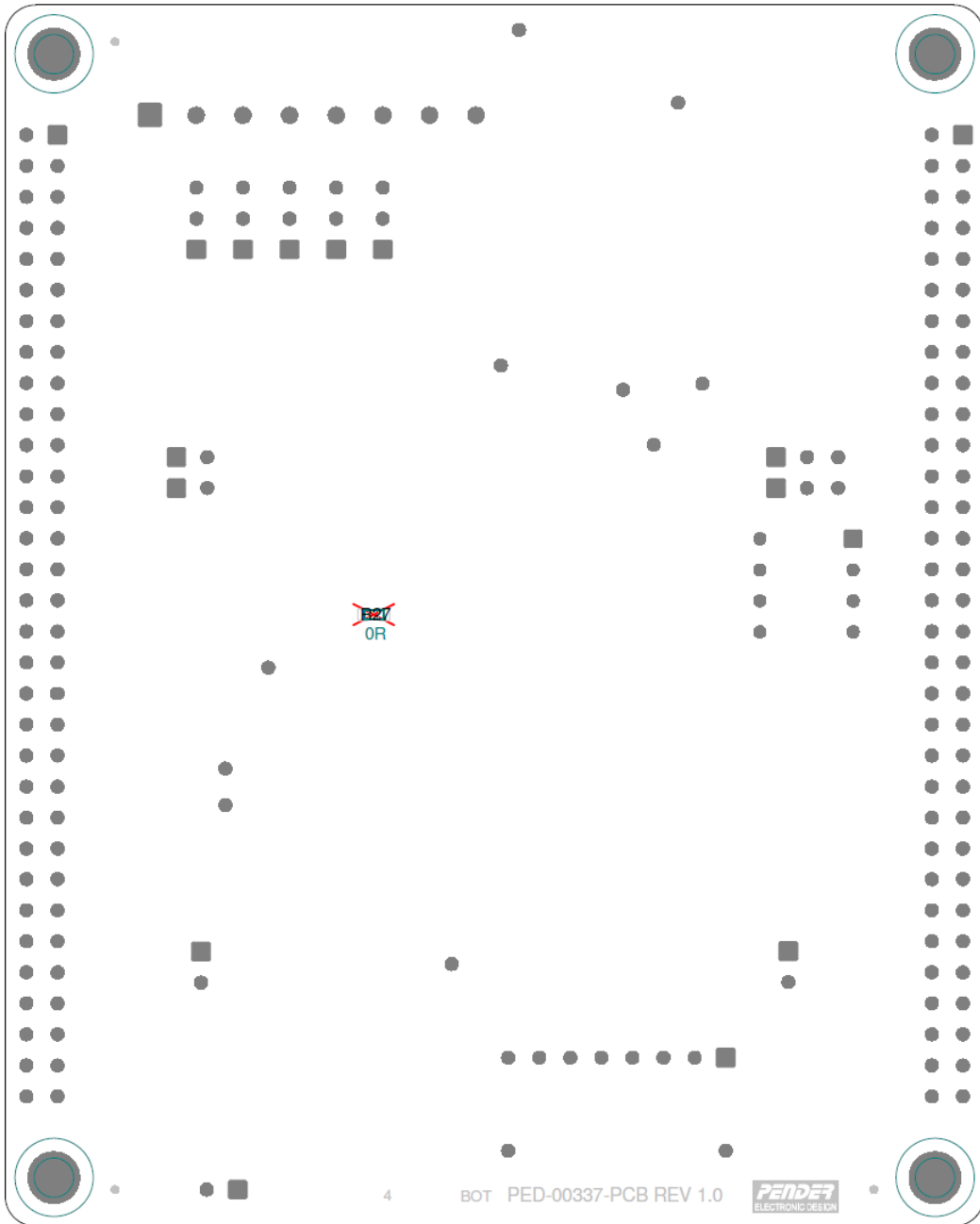

Figure 6-2 PCB Bottom View



Figure 6-3 PCB Top View (Photo)

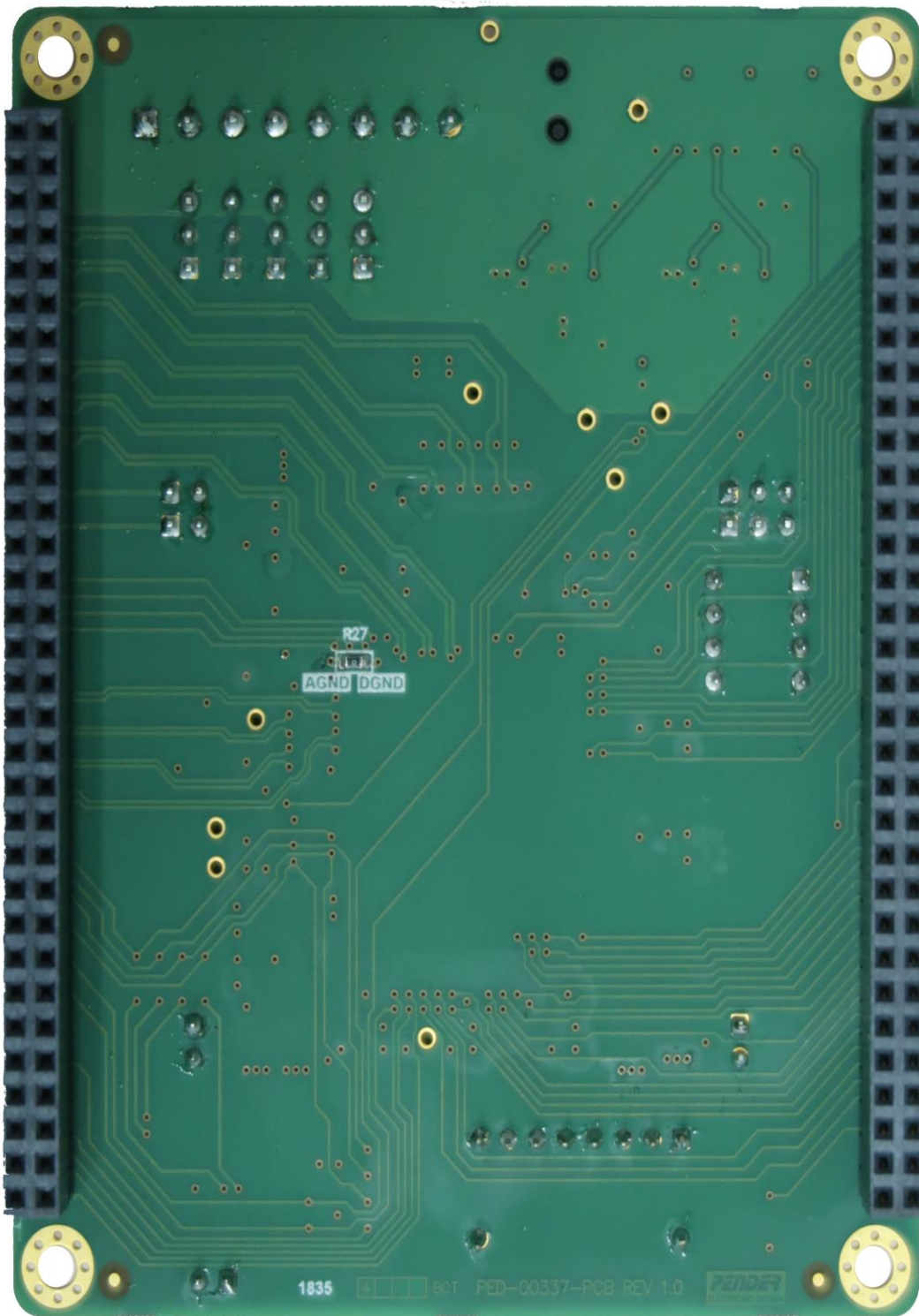

Figure 6-4 PCB Bottom View (Photo)

REVISION INFORMATION

Issue	Date	Section / Page	Description
0.0	2024-05-13	All	Draft Issue
0.1	2019-05-02	All	Corrected bootstrap signals and start-up behaviour for default configuration
1.0	2023-10-19	All 4.5	Updated company name and document template Handling instructions for LVDS added
1.1	2024-05-13	4.10	Jumper positions corrected

Frontgrade Gaisler AB
Kungsgatan 12
411 19 Göteborg
Sweden
www.frontgrade.com/gaisler
sales@gaisler.com
T: +46 31 7758650

Frontgrade Gaisler AB reserves the right to make changes to any products and services described herein at any time without notice. Consult the company or an authorized sales representative to verify that the information in this document is current before using this product. The company does not assume any responsibility or liability arising out of the application or use of any product or service described herein, except as expressly agreed to in writing by the company; nor does the purchase, lease, or use of a product or service from the company convey a license under any patent rights, copyrights, trademark rights, or any other of the intellectual rights of the company or of third parties. All information is provided as is. There is no warranty that it is correct or suitable for any purpose, neither implicit nor explicit.

Copyright © 2024 Frontgrade Gaisler AB